



ANSI/TI A-1096-A  
Approved: March 17, 2008

# TIA STANDARD

---

## Telecommunications

## Telephone Terminal Equipment

## Connector Requirements for Connection of Terminal Equipment to the Telephone Network

---

**TIA-1096-A**

March 2008

---

**TELECOMMUNICATIONS INDUSTRY ASSOCIATION**



Representing the telecommunications industry in  
association with the Electronic Industries Alliance



Adopted by the ACTA  
May 6, 2008

## NOTICE

TIA Engineering Standards and Publications are designed to serve the public interest through eliminating misunderstandings between manufacturers and purchasers, facilitating interchangeability and improvement of products, and assisting the purchaser in selecting and obtaining with minimum delay the proper product for their particular need. The existence of such Standards and Publications shall not in any respect preclude any member or non-member of TIA from manufacturing or selling products not conforming to such Standards and Publications. Neither shall the existence of such Standards and Publications preclude their voluntary use by Non-TIA members, either domestically or internationally.

Standards and Publications are adopted by TIA in accordance with the American National Standards Institute (ANSI) patent policy. By such action, TIA does not assume any liability to any patent owner, nor does it assume any obligation whatever to parties adopting the Standard or Publication.

This Standard does not purport to address all safety problems associated with its use or all applicable regulatory requirements. It is the responsibility of the user of this Standard to establish appropriate safety and health practices and to determine the applicability of regulatory limitations before its use.

(From Standards Proposal No. 3-0235-RV1, formulated under the cognizance of the TIA, TR-41 User Premises Telecommunications Requirements. TR-41.9 Subcommittee on Technical and Administrative Regulatory Considerations).

Published by

©TELECOMMUNICATIONS INDUSTRY ASSOCIATION  
Standards and Technology Department  
2500 Wilson Boulevard  
Arlington, VA 22201 U.S.A.

**PRICE: Please refer to current Catalog of  
TIA TELECOMMUNICATIONS INDUSTRY ASSOCIATION STANDARDS  
AND ENGINEERING PUBLICATIONS  
or call IHS USA and Canada  
(1-800-525-7052 ) International (303-790-0600)  
or search online at <http://www.tiaonline.org/standards/catalog/>**

All rights reserved  
Printed in U.S.A.

# NOTICE OF COPYRIGHT

**This document is copyrighted by the TIA.**

**Reproduction of these documents either in hard copy or soft copy (including posting on the web) is prohibited without copyright permission.** For copyright permission to reproduce portions of this document, please contact TIA Standards Department or go to the TIA website ([www.tiaonline.org](http://www.tiaonline.org)) for details on how to request permission. Details are located at:

<http://www.tiaonline.org/standards/catalog/info.cfm#copyright>

OR

Telecommunications Industry Association  
Standards & Technology Department  
2500 Wilson Boulevard, Suite 300  
Arlington, VA 22201 USA  
+1(703)907-7700

Organizations may obtain permission to reproduce a limited number of copies by entering into a license agreement. For information, contact:

IHS  
15 Inverness Way East  
Englewood, CO 80112-5704 or call  
U.S.A. and Canada(1-877-413-5187)  
International (303-397-2896)



## **NOTICE OF DISCLAIMER AND LIMITATION OF LIABILITY**

The document to which this Notice is affixed (the “Document”) has been prepared by one or more Engineering Committees or Formulating Groups of the Telecommunications Industry Association (“TIA”). TIA is not the author of the Document contents, but publishes and claims copyright to the Document pursuant to licenses and permission granted by the authors of the contents.

TIA Engineering Committees and Formulating Groups are expected to conduct their affairs in accordance with the TIA Engineering Manual (“Manual”), the current and predecessor versions of which are available at <http://www.tiaonline.org/standards/procedures/manuals/> TIA’s function is to administer the process, but not the content, of document preparation in accordance with the Manual and, when appropriate, the policies and procedures of the American National Standards Institute (“ANSI”). TIA does not evaluate, test, verify or investigate the information, accuracy, soundness, or credibility of the contents of the Document. In publishing the Document, TIA disclaims any undertaking to perform any duty owed to or for anyone.

If the Document is identified or marked as a project number (PN) document, or as a standards proposal (SP) document, persons or parties reading or in any way interested in the Document are cautioned that: (a) the Document is a proposal; (b) there is no assurance that the Document will be approved by any Committee of TIA or any other body in its present or any other form; (c) the Document may be amended, modified or changed in the standards development or any editing process.

The use or practice of contents of this Document may involve the use of intellectual property rights (“IPR”), including pending or issued patents, or copyrights, owned by one or more parties. TIA makes no search or investigation for IPR. When IPR consisting of patents and published pending patent applications are claimed and called to TIA’s attention, a statement from the holder thereof is requested, all in accordance with the Manual. TIA takes no position with reference to, and disclaims any obligation to investigate or inquire into, the scope or validity of any claims of IPR. TIA will neither be a party to discussions of any licensing terms or conditions, which are instead left to the parties involved, nor will TIA opine or judge whether proposed licensing terms or conditions are reasonable or non-discriminatory. TIA does not warrant or represent that procedures or practices suggested or provided in the Manual have been complied with as respects the Document or its contents.

If the Document contains one or more Normative References to a document published by another organization (“other SSO”) engaged in the formulation, development or publication of standards (whether designated as a standard, specification, recommendation or otherwise), whether such reference consists of mandatory, alternate or optional elements (as defined in the TIA Engineering Manual, 4<sup>th</sup> edition) then (i) TIA disclaims any duty or obligation to search or investigate the records of any other SSO for IPR or letters of assurance relating to any such Normative Reference; (ii) TIA’s policy of encouragement of voluntary disclosure (see Engineering Manual Section 6.5.1) of Essential Patent(s) and published pending patent applications shall apply; and (iii) Information as to claims of IPR in the records or publications of the other SSO shall not constitute identification to TIA of a claim of Essential Patent(s) or published pending patent applications.

TIA does not enforce or monitor compliance with the contents of the Document. TIA does not certify, inspect, test or otherwise investigate products, designs or services or any claims of compliance with the contents of the Document.

**ALL WARRANTIES, EXPRESS OR IMPLIED, ARE DISCLAIMED, INCLUDING WITHOUT LIMITATION, ANY AND ALL WARRANTIES CONCERNING THE ACCURACY OF THE CONTENTS, ITS FITNESS OR APPROPRIATENESS FOR A PARTICULAR PURPOSE OR USE, ITS MERCHANTABILITY AND ITS NONINFRINGEMENT OF ANY THIRD PARTY’S INTELLECTUAL PROPERTY RIGHTS. TIA EXPRESSLY DISCLAIMS ANY AND ALL RESPONSIBILITIES FOR THE ACCURACY OF THE CONTENTS AND MAKES NO REPRESENTATIONS OR WARRANTIES REGARDING THE CONTENT’S COMPLIANCE WITH ANY APPLICABLE STATUTE, RULE OR REGULATION, OR THE SAFETY OR HEALTH EFFECTS OF THE CONTENTS OR ANY PRODUCT OR SERVICE REFERRED TO IN THE DOCUMENT OR PRODUCED OR RENDERED TO COMPLY WITH THE CONTENTS.**

TIA SHALL NOT BE LIABLE FOR ANY AND ALL DAMAGES, DIRECT OR INDIRECT, ARISING FROM OR RELATING TO ANY USE OF THE CONTENTS CONTAINED HEREIN, INCLUDING WITHOUT LIMITATION ANY AND ALL INDIRECT, SPECIAL, INCIDENTAL OR CONSEQUENTIAL DAMAGES (INCLUDING DAMAGES FOR LOSS OF BUSINESS, LOSS OF PROFITS, LITIGATION, OR THE LIKE), WHETHER BASED UPON BREACH OF CONTRACT, BREACH OF WARRANTY, TORT (INCLUDING NEGLIGENCE), PRODUCT LIABILITY OR OTHERWISE, EVEN IF ADVISED OF THE POSSIBILITY OF SUCH DAMAGES. THE FOREGOING NEGATION OF DAMAGES IS A FUNDAMENTAL ELEMENT OF THE USE OF THE CONTENTS HEREOF, AND THESE CONTENTS WOULD NOT BE PUBLISHED BY TIA WITHOUT SUCH LIMITATIONS.

## Table of Contents

<b>1</b>	<b>SCOPE AND APPLICATION .....</b>	<b>1</b>
1.1	SCOPE.....	1
1.2	APPLICATION.....	1
1.3	IMPLEMENTATION DATES .....	1
<b>2</b>	<b>NORMATIVE REFERENCES.....</b>	<b>1</b>
<b>3</b>	<b>DEFINITIONS AND ACRONYMS .....</b>	<b>2</b>
<b>4</b>	<b>PHYSICAL REQUIREMENTS.....</b>	<b>2</b>
4.1	GENERAL.....	2
4.2	UNITS OF MEASURE .....	3
4.3	INDIVIDUAL PLUGS AND JACKS.....	3
4.3.1	Miniature 6-Position Plug.....	4
4.3.2	Miniature 6-Position Jack .....	11
4.3.3	Miniature 8-Position Plug, Unkeyed: .....	14
4.3.4	Miniature 8-Position Series Jack .....	21
4.3.5	50-Position Miniature Ribbon Plug .....	24
4.3.6	50-Position Miniature Ribbon Jack.....	29
4.3.7	3-Position Weatherproof Plug.....	33
4.3.8	3-Position Weatherproof Jack .....	34
4.3.9	Miniature 8-Position Plug, Keyed .....	35
4.3.10	Miniature 8-Position Keyed Jack .....	42
<b>5</b>	<b>CONTACT REQUIREMENTS .....</b>	<b>45</b>
5.1	HARD GOLD CONTACTS .....	45
5.1.1	Gold Surface Layer.....	45
5.1.2	Nickel Barrier Layer .....	45
5.2	CONTACTS USING ALTERNATIVE MATERIALS.....	45
5.2.1	Sample Selection.....	46
5.2.2	Mating and Unmating Forces Test .....	46
5.2.3	Durability Test.....	46
5.2.4	Contact Resistance .....	47
5.2.5	Temperature and Humidity Cycling Test .....	48
5.2.6	Mixed Flowing Gas Test.....	49
<b>6</b>	<b>WIRING CONFIGURATIONS.....</b>	<b>49</b>
	<b>ANNEX A (Informative) – MODIFIED SO<sub>2</sub> TEST METHOD .....</b>	<b>50</b>
	<b>ANNEX B (Normative) – MIXED FLOWING GAS TEST.....</b>	<b>51</b>

## List of Figures

Figure 4-1: View of Miniature 6-Position Plug.....	4
Figure 4-2: 6-Position Plug Mechanical Specification.....	5
Figure 4-3: 6-Position Plug Mechanical Specification (continued).....	6
Figure 4-4: 6-Position Plug Plug/Jack Contact Specification.....	7
Figure 4-5: 6-Position Plug Minimum Plug Size.....	9
Figure 4-6: 6-Position Plug Maximum Plug Size.....	10
Figure 4-7: 6-Position Jack Mechanical Specification.....	11
Figure 4-8: 6-Position Jack Mechanical Specifications (continued).....	12
Figure 4-9: View of Miniature 8-Position Plug, Unkeyed.....	14
Figure 4-10: 8-Position Unkeyed Plug Mechanical Specification.....	15
Figure 4-11: 8-Position Unkeyed Plug, Mechanical Specification (continued).....	16
Figure 4-12: 8-Position Unkeyed Plug, Plug/Jack Contact Specification.....	17
Figure 4-13: 8-Position Unkeyed Plug, Minimum Plug Size.....	19
Figure 4-14: 8-Position Unkeyed Plug, Maximum Plug Size.....	20
Figure 4-15: 8-Position Series Jack, Contact Specification.....	21
Figure 4-16: 8-Position Series Jack, Mechanical Specification.....	21
Figure 4-17: 8-Position Series Jack, Mechanical Specification (continued).....	22
Figure 4-18: 50-Position Miniature Ribbon Plug.....	24
Figure 4-19: 50-Position Miniature Ribbon Plug Sizing Gauge.....	25
Figure 4-20: 50-Position Miniature Ribbon Plug Continuity Gauge.....	26
Figure 4-21: 50-Position Miniature Ribbon Plug Hood Envelope.....	28
Figure 4-22: 50-Position Miniature Ribbon Jack.....	29
Figure 4-23: 50-Position Miniature Ribbon Jack Sizing Gauge.....	30
Figure 4-24: 50-Position Miniature Ribbon Jack Continuity Gauge.....	31
Figure 4-25: 3-Position Plug, Plug Assembly.....	33
Figure 4-26: 3-Position Plug, Detail.....	33
Figure 4-27: 3-Position Jack, Detail.....	34
Figure 4-28: View of Miniature 8-Position Plug, Keyed.....	35
Figure 4-29: 8-Position Keyed Plug, Mechanical Specification.....	36
Figure 4-30: 8-Position Keyed Plug, Mechanical Specification (continued).....	36
Figure 4-31: 8-Position Keyed Plug, Plug/Jack Contact Specification.....	38
Figure 4-32: 8-Position Keyed Plug, Maximum Plug Size.....	40
Figure 4-33: 8-Position Keyed Plug, Minimum Plug Size.....	41
Figure 4-34: View of Miniature 8-Position Keyed Jack.....	42
Figure 4-35: 8-Position Keyed Jack, Mechanical Specification.....	43
Figure 5-1: Contact Resistance Connections.....	48
Table B- 1: Environmental Severity Limits.....	55
Figure B- 1: Chamber Zone Configuration.....	58
Figure B- 2: Control Coupon Locations.....	59



## FOREWORD

(This foreword is not part of this Standard.)

The requirements concerning mechanical characteristics and dimensions of the plug and jack connectors described in this document were originally contained in Subpart F of Part 68 of the Federal Communication Commission (FCC) Rules. When the Commission created the Administrative Council for Terminal Attachments (ACTA) in Report & Order FCC 00-400 on CC Docket No. 99-216, it turned over responsibility for maintaining most of the technical criteria in Part 68 to industry. In compliance with one of the provisions of that Report & Order, the Telecommunications Industry Association (TIA) created Interim Standard IS-968 to provide an initial set of technical criteria identical to that which then existed in Part 68. Thus, the Part 68, Subpart F connector requirements were included in TIA IS-968 that was adopted by the ACTA in 2001. In 2002, TIA IS-968 was superseded by TIA-968-A, which was also adopted by the ACTA.

The original Part 68, Subpart F specifications included requirements that 6-position and 8-position modular connector contacts provide a hard gold to hard gold interface, or equivalent, when a plug and jack were mated. In Docket No. 88-57, the FCC requested the Electronic Industries Alliance (EIA) to develop a procedure for demonstrating the equivalency of alternative contact materials to hard gold. In 1989, TIA Subcommittee TR-41.9 included such a procedure in its Telecommunications Systems Bulletin EIA/TIA TSB-31 on suggested Part 68 test methods.

In its work to revise TSB-31-B, TR-41.9 was reminded that TSBs are intended to provide guidance, not contain mandatory requirements. However, separating the test procedure from the requirements for determining the hard gold equivalence of alternative contact materials proved extremely challenging. A solution was found by removing the requirements concerning mechanical characteristics and dimensions of the plug and jack connectors from TIA-968-A and combining them with test procedures and requirements for hard gold and alternative contact materials from TSB-31-B into this new standard, TIA-1096.

An error was found in Figures 4-29 and 4-30 of TIA-1096 after it had been approved and submitted to ACTA for adoption. Although the figures were identified as showing an 8-position keyed plug, they actually depicted an un-keyed plug. Further checking found this error first occurred in IS-968 and had continued to be perpetuated. This revision of TIA-1096 corrects that error by properly depicting an 8-position keyed plug as originally shown in Subpart F of Part 68.

This standard was produced by Subcommittee TR-41.9, Technical and Administrative Regulatory Considerations. It was developed in accordance with ANSI and TIA procedural guidelines and represents the consensus position of the Subcommittee, which served as the formulating group. It has also received the concurrence of Engineering Committee TR-41, User Premises Telecommunications Requirements.

Subcommittee TR-41.9 acknowledges the written contributions and leadership provided by the following individuals to the development of this standard:

<b>Organization</b>	<b>Representative</b>	<b>Previous Version</b>	<b>TIA-1096-A</b>
Littelfuse	Phillip Havens	✓	Chair
Mitel	Greg Slingerland	Chair	–
VTech	Steve Whitesell	Editor	Editor
Sprint	Cliff Chamney	✓	–
Thomson	Roger Hunt	✓	–
Verizon	Trone Bishop	✓	✓

Suggestions for improvement of this standard are welcome. They should be sent to:

Telecommunications Industry Association  
 Engineering Department  
 Suite 300  
 2500 Wilson Boulevard  
 Arlington, VA 22201

# 1 SCOPE AND APPLICATION

## 1.1 SCOPE

The technical criteria in this standard are intended to protect the telephone network from the harms defined by the Federal Communications Commission (FCC) Part 68, Section 3 rules in Title 47 of the Code of Federal Regulations (47 CFR 68.3). This standard specifies physical dimensions, mechanical characteristics, and contact material requirements for:

1. Carrier-installed jacks used at the demarcation point in accordance with 47 CFR 68.105(a);
2. Plugs and jacks used with inside wiring in accordance with 47 CFR 68.213(b);
3. Plugs and jacks used to connect terminal equipment to wireline carrier networks.

This standard outlines test methods for determining compliance with the requirements for hard gold contacts. Additionally it outlines a test method for determining equivalency to hard gold plating performance for alternative contact materials.

## 1.2 APPLICATION

Two categories of specifications are used in this standard, mandatory requirements and recommendations. Mandatory requirements are designated by the words "shall" and "shall not" and recommendations by the words "should" and "should not".

The notes to figures in clause 4 of this document contain mandatory requirements.

This standard was specifically developed for submission to the Administrative Council for Terminal Attachments (ACTA). It is intended to supersede the technical criteria in clause 6.1 of TIA-968-A and the criteria that clause references in clause 15 and Appendices D and E of TIA-TSB-31B.

Testing of connectors for compliance with this standard should be carried out under normal laboratory conditions of 20°C to 25°C and 20% to 60% relative humidity unless otherwise specified.

## 1.3 IMPLEMENTATION DATES

The criteria in this revision of the standard may be applied to terminal equipment approved after publication of this document (TIA-1096-A) by the ACTA.

The criteria in this revision of the standard shall be applied to terminal equipment approved 6 months after publication of this document (TIA-1096-A) by the ACTA.

# 2 NORMATIVE REFERENCES

The following standards contain provisions, which, through reference in this text, constitute provisions of this standard. At the time of publication, the editions indicated were valid. All standards are subject to revision, and parties to agreements based on this

standard are encouraged to investigate the possibility of applying the most recent editions of the standards indicated below. ANSI and TIA maintain registers of currently valid national standards.

1. ASTM E384-05a, *Standard Test Method for Microindentation Hardness of Materials*
2. EIA-364-09C-1999, *Durability Test Procedure for Electrical Connectors and Contacts*
3. EIA-364-13B-1998, *Mating and Unmating Forces Test Procedures for Electrical Connectors*
4. EIA-364-53B-2000, *Nitric Acid Vapor Test, Gold Finish Test Procedure for Electrical Connectors and Sockets*
5. IEC 60512-2-1, *Connectors for Electronic Equipment – Tests and Measurements – Part 2-1: Electrical Continuity and Contact Resistance Tests – Test 2a: Contact Resistance – Millivolt Level Method*
6. T1.TR.5-1999, *Network and Customer Installation Interface Connector Wiring Configuration Catalog*

### 3 DEFINITIONS AND ACRONYMS

For the purposes of this standard, the following definitions apply.

**go gauge:** a gauge whose dimensions are such that the object being tested will be accepted.

**hard gold:** An alloy consisting primarily of pure gold with a small amount of a hardening agent such as cobalt or nickel.

**mating force:** The peak in-line force measured during insertion of a plug into its associated jack up to the point where the latching tab locks the plug in place.

**no-go gauge:** a gauge whose dimensions are such that the object being tested will not be accepted.

**unmating force:** The peak in-line force measured during removal of a plug from its associated jack with the latching tab unlocked from the jack.

### 4 PHYSICAL REQUIREMENTS

#### 4.1 GENERAL

The plugs and jacks described in this section represent the standard connectors to be used for connections to the telephone network. The plug and jack designs shown are representative of generic types, and should not be interpreted as the only designs that may be used. Design innovation and improvement is anticipated; but for interchangeability to be maintained, alternative designs shall be compatible with the plugs and jacks shown.

Hardware used to mount, protect, and enclose standard jacks is not described. The only requirement on connecting blocks, housings, dust covers, outdoor boxes, and the like that contain standard network jacks is that they shall accept standard plugs with cordage.

For special purpose applications, plugs may be made longer than shown or adapted for direct use on equipment or apparatus without cordage. The sliding modular plug used on the back of many modular wall telephone sets is an example of such a special purpose application. It is the responsibility of the designers and manufacturers of communication equipment who use such plugs to assure that they are compatible with the hardware used to mount standard jacks with which they plan to interface.

## **4.2 UNITS OF MEASURE**

US customary units were the original dimensional units used in designing the plugs and jacks specified by this document and are shown in parentheses throughout this section. The dimensions shown without parenthesis are in SI (Système International) units (i.e. the International System of measurement).

The SI dimensional units are derived from the US customary units by multiplying inches by 25.4 to derive the exact conversion in millimeters with no rounding-off of the resulting decimal value. The number of decimal places to which the conversion is taken is governed by the concept that when the calculated SI dimensional unit is divided by 25.4, the resulting inches calculation will be exactly that shown in the parenthesis (the original design dimension).

The conversion to SI force units, Newtons (N), is rounded off to a number of decimal places that will result in the calculated SI force value being within less than 1% of the original US customary force unit value located adjacent in parenthesis (the original design value). The rationale for this is to bring the force conversions to within the degree of accuracy of the force-measuring device and avoid the carrying of an unrealistic number of decimal places that would otherwise result from an exact conversion.

## **4.3 INDIVIDUAL PLUGS AND JACKS**

The figures and corresponding notes in the following subclauses contain the mechanical and dimensional requirements for several different types of connectors. If alternative designs are used, the interface dimensions between mating plugs and jacks shall be maintained.

Where a hard gold to hard gold contact is specified, the hard gold surface shall meet the requirements of 5.1. Where an alternative to hard gold contact material is allowed, the contact material shall be compatible with hard gold contacts meeting the requirements of 5.1 and shall provide equivalent contact performance as specified in 5.2.

### 4.3.1 Miniature 6-Position Plug

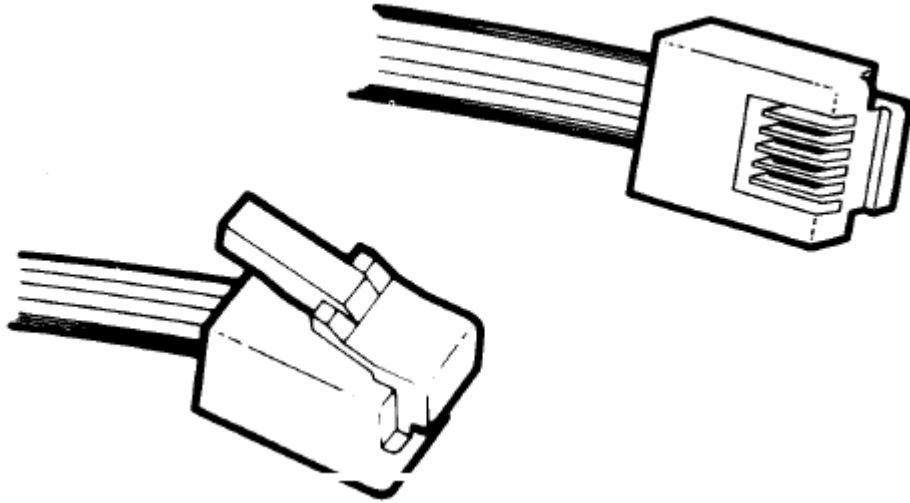

NOTE: This plug is depicted equipped with 4 contacts. It may be fabricated with 2, 4, or 6 contacts.

**Figure 4-1: View of Miniature 6-Position Plug**

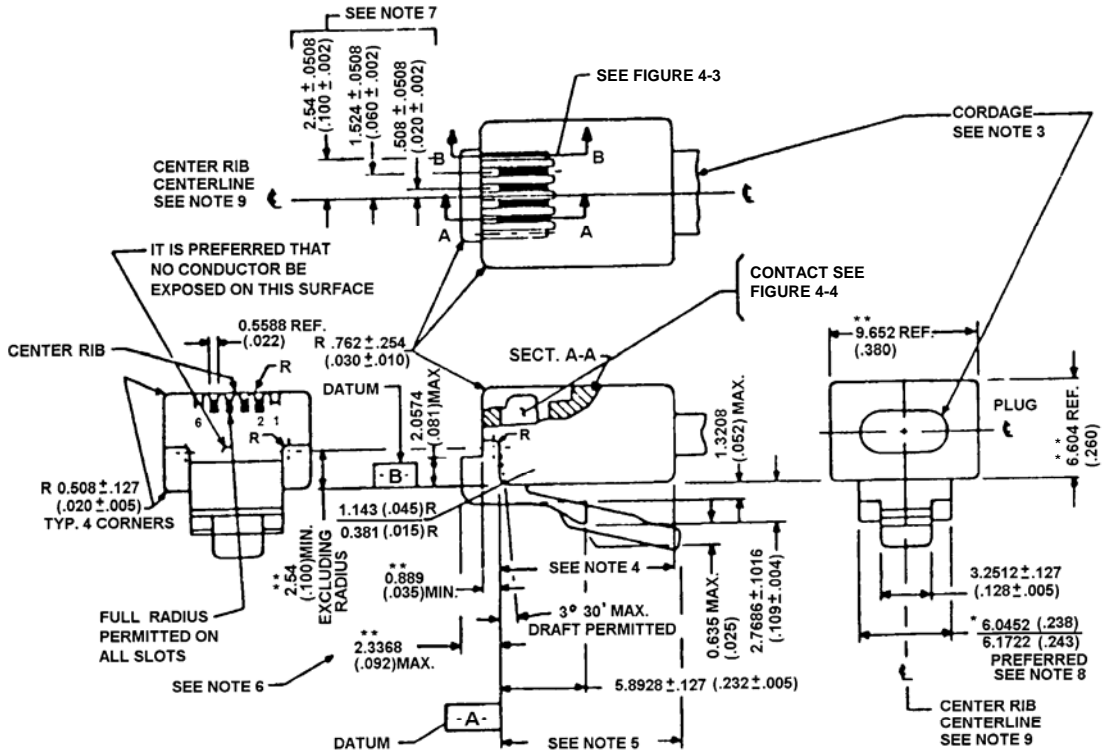

- \*  $\frac{6.0452 (.238)}{6.1722 (.243)}$  DIMENSION TO BE LOCATED CENTRALLY  
LOCATED ABOUT CENTER RIB CENTERLINE WITHIN  $\pm 0.0762 (\pm .003)$
- \*\* SEE GAUGE REQUIREMENTS  
FIGURES 4-5 & 4-6

Figure 4-2: 6-Position Plug Mechanical Specification

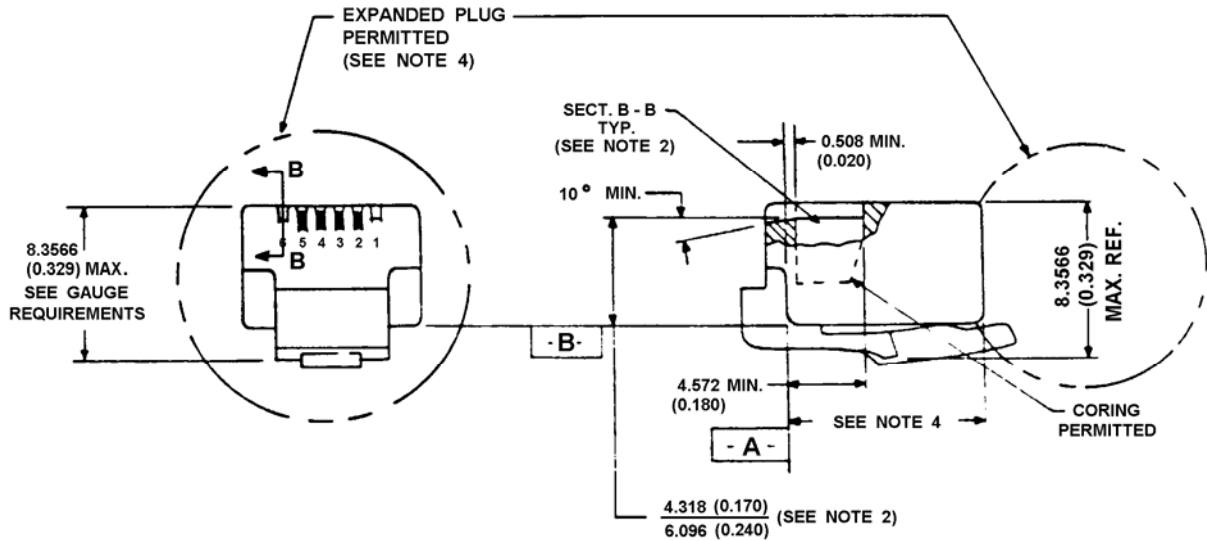

**Figure 4-3: 6-Position Plug Mechanical Specification (continued)**

**NOTES to Figures 4-2 and 4-3:**

1. All plugs shall be capable of meeting the requirements of the go and no-go gauges shown in Figures 4-5 and 4-6.
2. Section BB applies to any jack contact receiving slot that does not contain a plug contact.
3. The major cordage cross section should be 2.5400 mm (0.100 in) max. thick by 5.0800 mm (0.200 in) max. wide, with rounded corners. It should exit the plug on the plug centerline. Other cordage configurations are permitted but may inhibit the special features of some network jack enclosures.
4. The standard plug length shall be 11.6840 mm (0.460 in) max. Plugs may be made longer than standard or adapted for direct use on special cords, adapters without cordage, and on apparatus or equipment. Plugs longer than standard could inhibit the special features of some network jack enclosures. It is the responsibility of the designers and manufacturers of communication equipment who use such plugs to assure that they are compatible with the hardware used to mount standard jacks with which they plan to interface.
5. A 12.0396 mm (0.474 in) minimum tab length shall be required. A maximum tab length should be no longer than 13.2080 mm (0.520 in). Longer tabs may be used with the same limitations as described in Note 4 to Figures 4-2 and 4-3.
6. To obtain maximum plug guidance when 6-position plugs are inserted in 8-position jacks, the front plug nose should be extended to the 2.3368 mm (0.092 in) maximum.
7. These dimensions shall apply to the location of jack contact receiving slots. Plug contacts should be centered axially in these slots.



8. The 6.0452/6.1722 mm (0.238/0.243 in) dimension normally shall be used to obtain maximum plug guidance in jacks with more than 6 contact positions. A tolerance range of 5.9182/6.1722 mm (0.233/0.243 in) is permitted, but could create targeting problems in 8-position jacks.
9. The center rib centerline shall be coincident with the plug width 9.6520 mm (0.380 in) ref. center line within +/- 0.0762 mm (+/- 0.003 in).

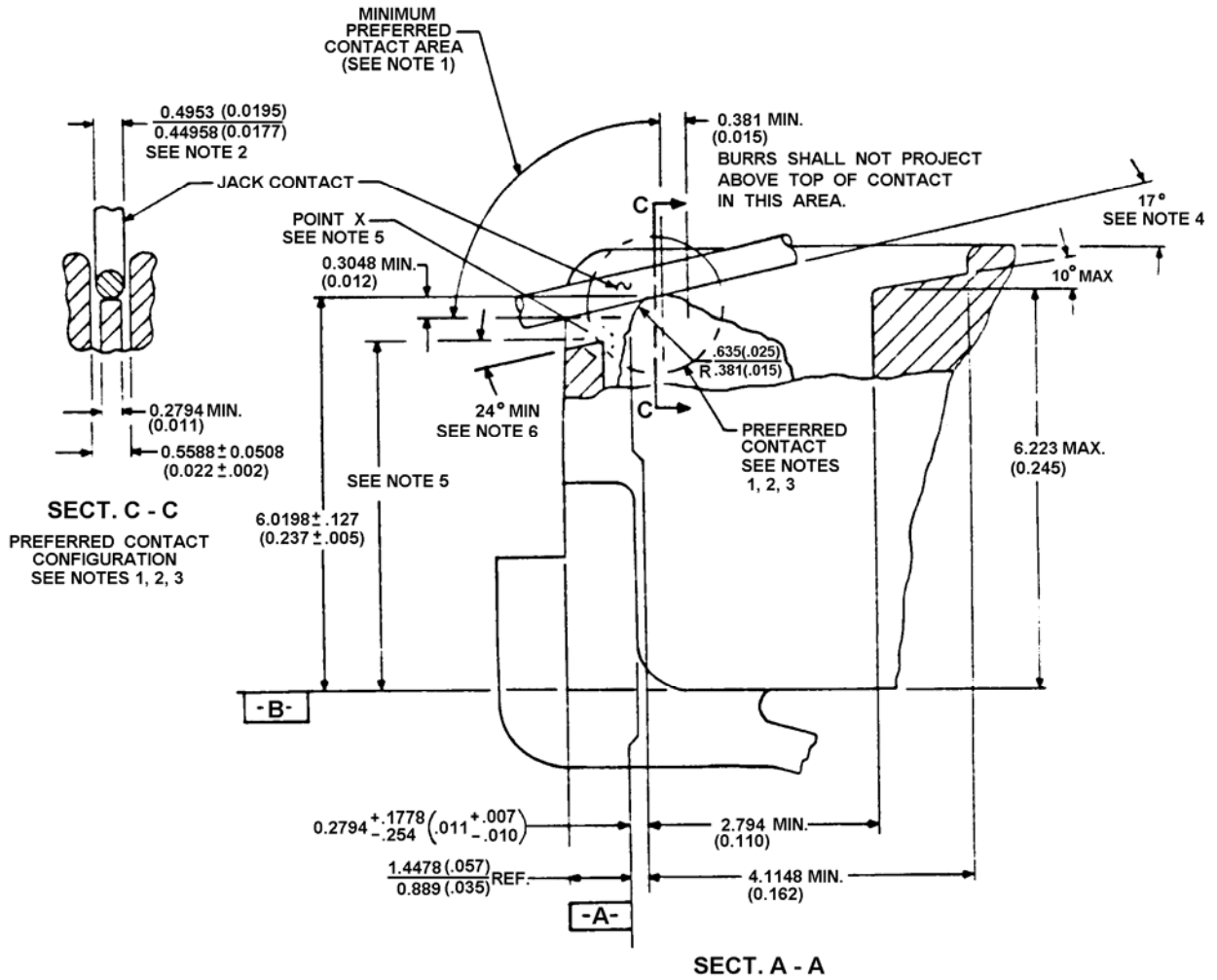

NOTE:- THE 8 POSITION PLUG / JACK CONTACT SPECIFICATION IS IDENTICAL

Figure 4-4: 6-Position Plug Plug/Jack Contact Specification

**NOTES to Figure 4-4:**

1. The plug/jack contact interface shall be hard gold to hard gold (see 5.1) and shall have a minimum gold thickness of 1.2700  $\mu\text{m}$  (50  $\mu\text{in}$ ) on each side of the interface. Alternative contact material that is compatible with hard gold and provides equivalent contact performance may be used under certain conditions (see 5.2). The minimum contact force at the interface shall be 0.98 N (100 g). A smooth, burr-free surface shall exist at the interface in the area shown. Contact surface roughness shall be 0.8128  $\mu\text{m}$  (32  $\mu\text{in}$ ) maximum. Compliance can be determined by observation with 10X magnification. Compare surface protrusions and burrs on the contact surface with a 32- $\mu\text{in}$ , ground-surface-finish gauge.
2. The jack contact design is based upon 0.4572 mm (0.018 in) spring temper phosphor bronze round wire in the modular plug blade and jack contact interface. Other contact configurations that provide contact performance equal to or better than the preferred configurations and do not cause damage to the plug or jack are permitted. The jack contact width should be 0.44958/0.49530 mm (0.0177/0.0195 in). Deviations from the preferred jack contact width are permitted for round contacts as well as noncircular cross sectional shapes but they shall be compatible with existing plug configurations. The requirements of Note 1 to Figure 4-4 shall apply to all possible contact areas.
3. The configuration of the plug contact and the front plastic of the plug shall prevent jack contacts from being damaged during plug insertion into jacks.
4. This nominal contact angle should be provided between plugs and jacks with the plug latched into the jack. This angle shall be less than 24° to avoid loss of electrical contact between the plug and jack. The nominal contact angle shall be greater than 13° to avoid interference between jack contacts and the internal plastic in the plug.
5. To avoid loss of electrical contact, the dimension from datum B to the highest point "X" should be 5.0800 mm (0.200 in) max. A dimension greater than 5.3594 mm (0.211 in) could result in loss of electrical contact between plugs and jacks. The 5.3594 mm (0.211 in) max. shall be considered an absolute maximum.
6. The 24° min. angle applies only to plugs with front plastic walls higher than 4.8260 mm (0.190 in).

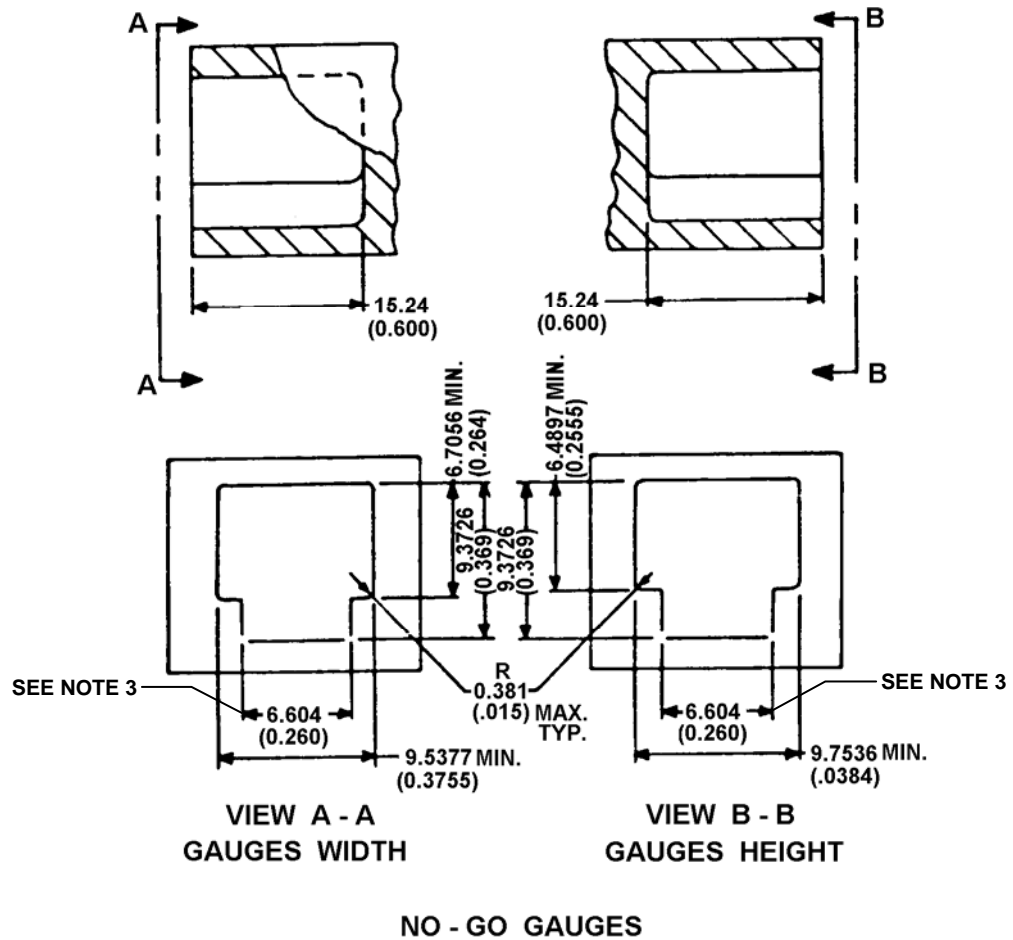

Figure 4-5: 6-Position Plug Minimum Plug Size

**NOTES to Figure 4-5:**

1. The plug shall not be capable of entering the gauge more than 1.778 mm (0.070) beyond datum -A- (see Figure 4-2) with 8.90 N (2.0 pounds) insertion force.
2. Dimensions not labelled as minimum or maximum shall be within  $\pm 0.0508$  mm (0.002).
3. 6.604 mm (0.260 in) dimension shall be centrally located with respect to 9.7536 mm (0.384 in) minimum and 9.5377 mm (0.3755 in) minimum dimensions within  $\pm 0.0508$  mm (0.002 in).

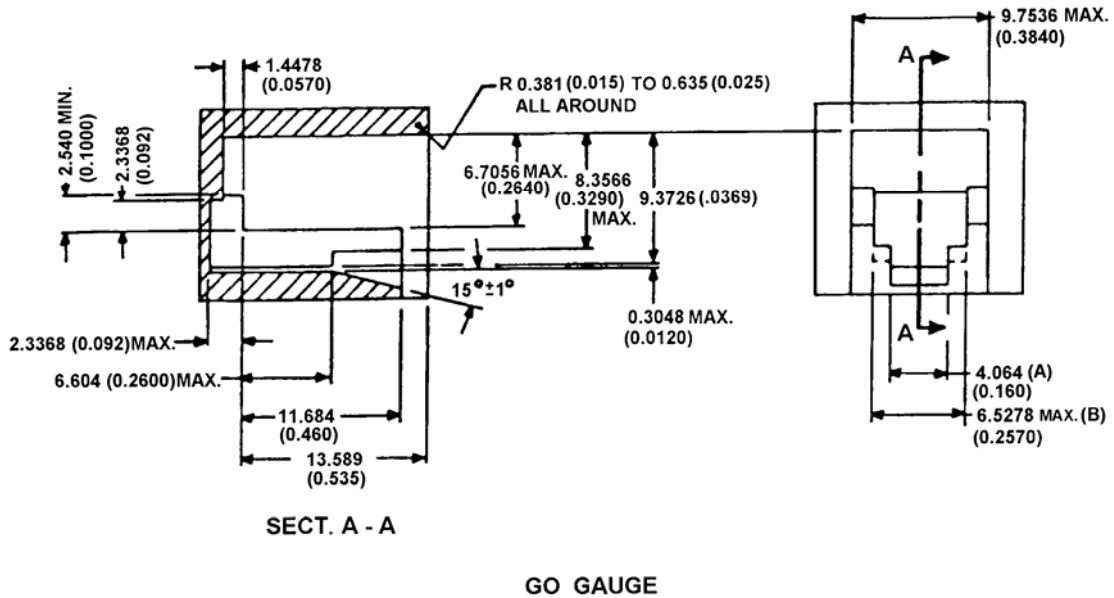

Figure 4-6: 6-Position Plug Maximum Plug Size

**NOTES to Figure 4-6:**

1. The plug shall be capable of insertion and latching into the gauge with 22.24 N (5 pounds) or less insertion force. Plug latching bar shall be depressed so as not to interfere with the plug entry. After insertion and latching, plug shall be capable of removal, with the latch depressed, with a removal force of 44.48 N (10 pounds) or less applied at an advantageous angle.
2. Dimensions not labelled as minimum or maximum shall be within  $\pm 0.0508$  mm ( $\pm 0.002$  in).
3. Dimensions (A) and (B) shall be centrally located with respect to 9.7536 mm (0.3840 in) max. Jack opening width within  $\pm 0.0254$  mm (0.001 in).

### 4.3.2 Miniature 6-Position Jack

NOTE: THIS JACK IS DEPICTED EQUIPPED WITH 4 CONTACTS. IT MAY BE FABRICATED WITH 2, 4, OR 6 CONTACTS.

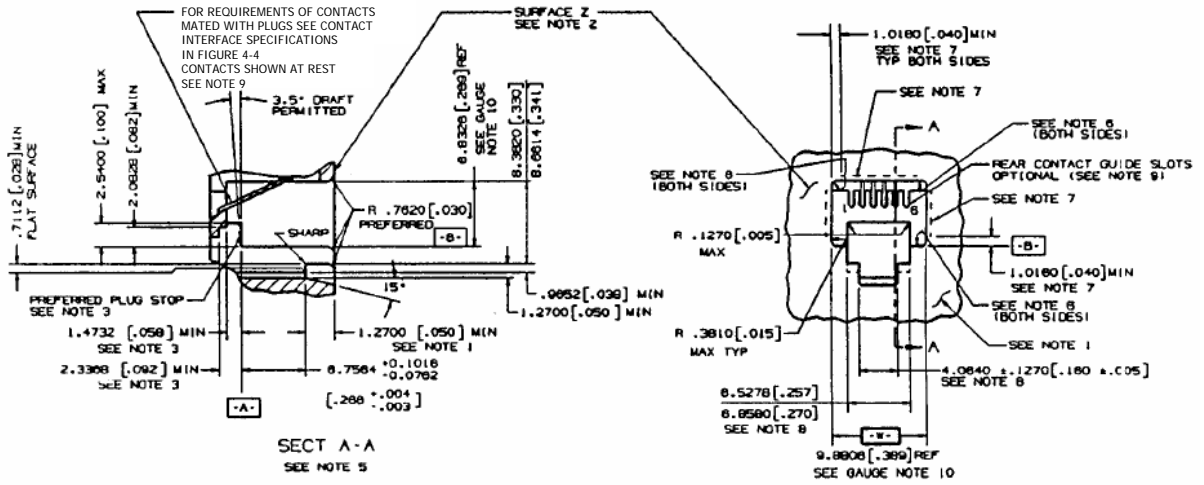

Figure 4-7: 6-Position Jack Mechanical Specification

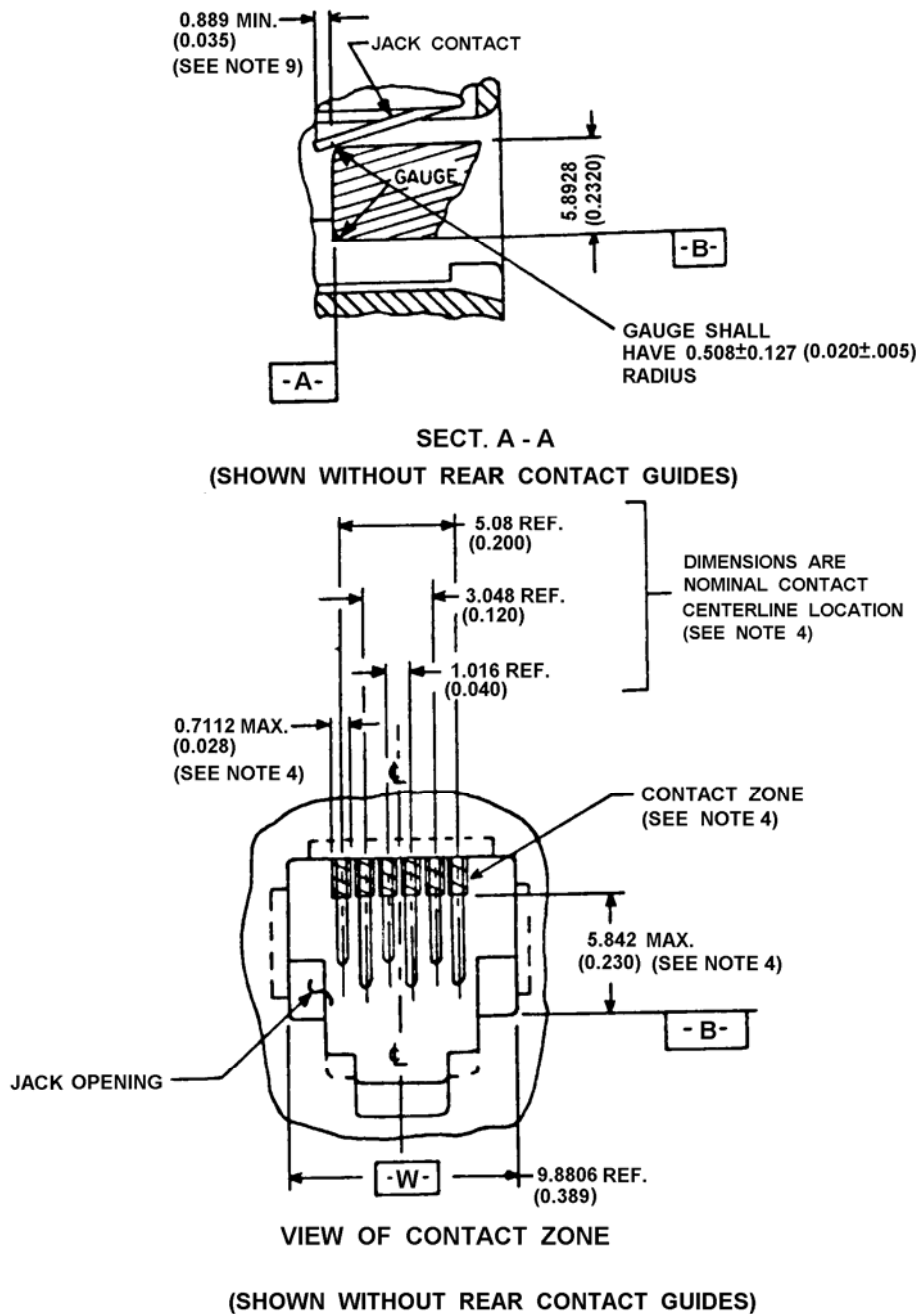

Figure 4-8: 6-Position Jack Mechanical Specifications (continued)

NOTES to Figures 4-7 and 4-8:

1. Front surface projections beyond the 1.2700 mm (0.050 in) min. shall be configured so as not to prevent finger access to the plug release catch (Reference Figure 4-2, 6-Position Plug, Mechanical Specifications). A catch length greater than 1.2700 mm (0.050 in) should be used to provide greater

breakout strength.

2. Surface Z need not be planar or coincident with the surface under the plug release catch. Surface Z projections shall not prevent insertion, latching, and unlatching of the standard 6-position plug of 4.3.1.
3. The indicated plug stop surface should be used. If some other internal feature is used as a plug stop, it shall be located so that the axial movement of a latched plug is no greater than 1.1430 mm (0.045 in).
4. To prevent mistargeting between the plug and jack contacts, the jack contacts shall be completely contained in their individual contact zones, 0.7112 mm (0.028 in) max. wide, where they extend into the jack openings. There is no location requirement for jack contacts below these zones 5.8420 mm (0.230 in) max., but adequate contact separation shall be maintained to prevent electrical breakdown. These shaded contact zones shall be centrally located, (included all locating tolerances), about the jack opening width 9.8806 mm (0.389 in) Ref, (Datum -W-). Contacts located outside of these zones could result in mistargeting between the jack and plug contacts.
5. All inside and outside corners in the plug cavity shall be 0.3810 mm (0.015 in) radius max. unless specified.
6. These surfaces shall have 0°15' maximum draft.
7. Relief inside the dotted areas on 3 sides of the jack opening is permitted. The 6.8326 mm (0.269 in) Ref and 9.8806 mm (0.389 in) Ref Gauge Requirements shall be maintained in each corner, (ref. 1.0160 mm (0.040 in) min), to assure proper plug/jack interface guidance. There shall be a  $0.8128 \pm 0.1270$  mm ( $0.032 \pm 0.005$ ) relief on the top side (opposite plug catch) on jacks in connecting blocks which mount and connect portable wall telephones so as to assure interface with the special purpose sliding modular plug used on many wall telephone sets.
8. 4.0640 mm (0.160 in) and 6.5278/6.8580 mm (0.257/0.270 in) dimensions shall be centrally located to jack opening width -W- within  $\pm 0.1778$  mm ( $\pm 0.007$  in).
9. Minimum acceptable jack contact length. When contact guide slots are used, the contacts shall always be contained inside the guide slots and the contacts shall move freely in the slots so as not to restrain plug insertion or damage jack contacts.
10. Gauge Requirements:
  - a. GO: The jack shall be capable of accepting a 9.7536 mm x 6.7056 mm (0.3840 in x 0.2640 in) gauge and the gauge shall be capable of being removed with a maximum force of 8.9 N (2 pounds).
  - b. NO GO: The jack shall not accept either a 10.00760 mm x 6.45160 mm (0.3940 in x 0.254 in) horizontal width of opening gauge or a 6.95960 mm x 9.5504 mm (0.2740 in x 0.376 in) vertical height of opening gauge. However, if either gauge is accepted the force necessary to remove the gauge shall be minimum 0.83 N (3.0 ounces).
  - c. Removal force requirements shall not include forces contributed by contact springs nor shall external forces be applied to the jack that will affect these removal forces.

- d. Gauges shall have a 0.7620 mm (0.030 in) radius on the nose and a 0.3810 mm (0.015 in) radius on all edges with clearance provided for contacts.

#### 4.3.3 Miniature 8-Position Plug, Unkeyed:

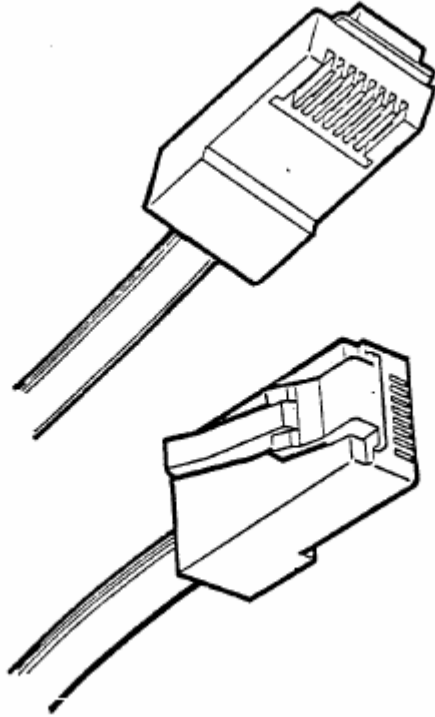

**Figure 4-9: View of Miniature 8-Position Plug, Unkeyed**



Note :- This plug is depicted with its full 8 contact capacity. It may be fabricated with less than 8 contacts.

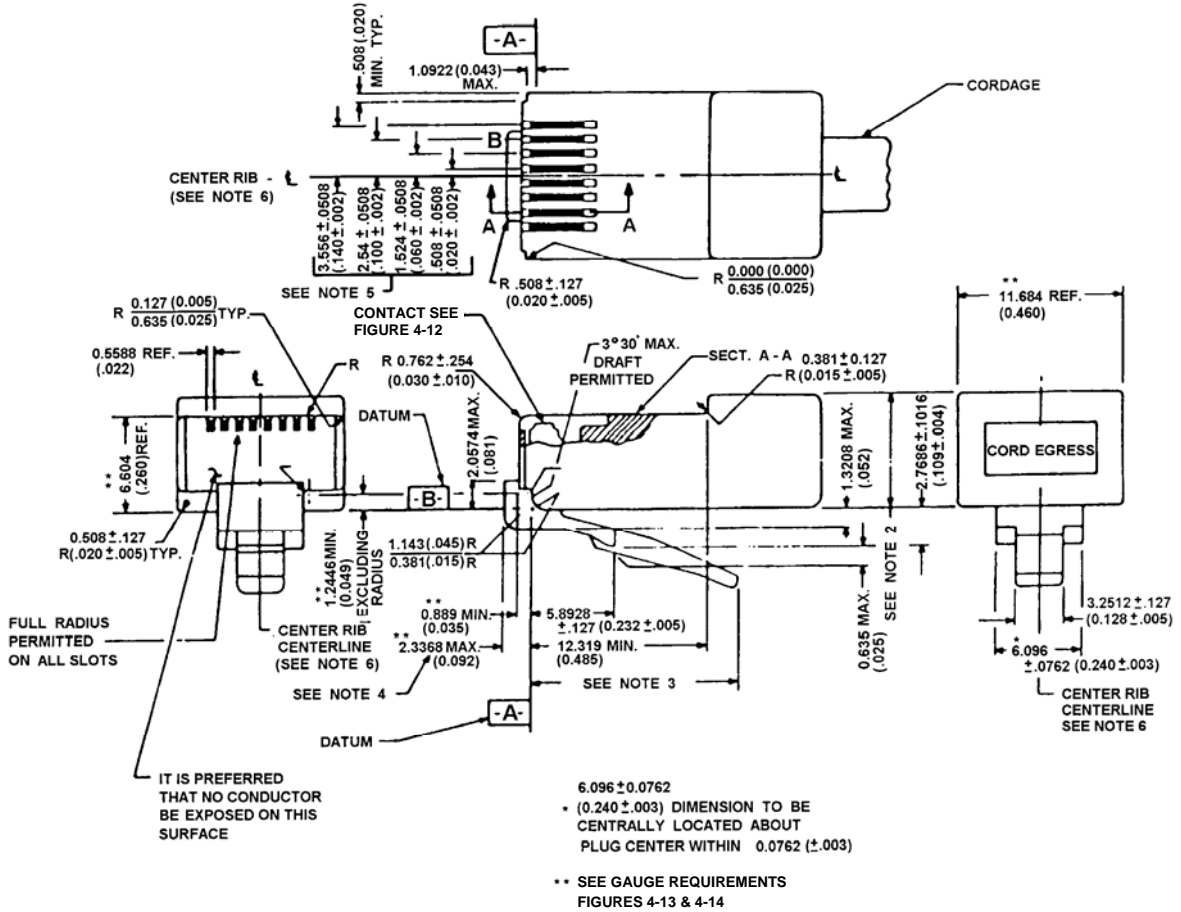
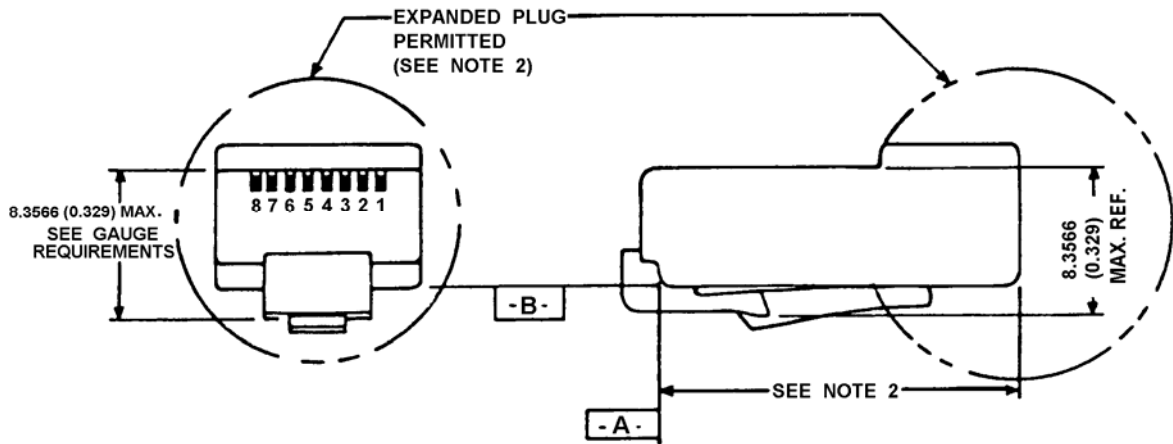

Figure 4-10: 8-Position Unkeyed Plug Mechanical Specification



**Figure 4-11: 8-Position Unkeyed Plug, Mechanical Specification (continued)**

**NOTES to Figures 4-10 and 4-11:**

1. All plugs shall be capable of meeting the requirements of the plug go and no-go gauges shown in Figures 4-13 and 4-14.
2. The standard plug height in the area shown shall be 8.0010 mm (0.315 in) maximum. The standard plug length shall be 23.1140 mm (0.910 in) maximum. Plugs may be made longer than standard or adapted for direct use on special cords, adapters without cordage, apparatus or equipment. Plugs longer and/ or higher than standard could inhibit the special features of some network jack enclosures. It is the responsibility of the designers and manufacturers of communication equipment who use such plugs to assure that they are compatible with the hardware used to mount standard jacks with which they plan to interface.
3. A 14.6050 mm (0.575 in) minimum tab length shall be provided. The maximum tab length should be no longer than 15.8750 mm (0.625 in). Longer tabs may be used with the same limitations described in Note 2 to Figures 4-10 and 4-11.
4. To obtain maximum plug guidance in jacks, the front plug nose should be extended to the 2.3368 mm (0.092 in) maximum.
5. These dimensions shall apply to the location of jack contact receiving slots. Plug contacts should be centered axially in these slots.
6. The center rib centerline shall be coincident with the plug width 11.6840 mm ref. (0.460 in ref.) centerline within  $\pm 0.0762$  mm ( $\pm 0.003$  in).

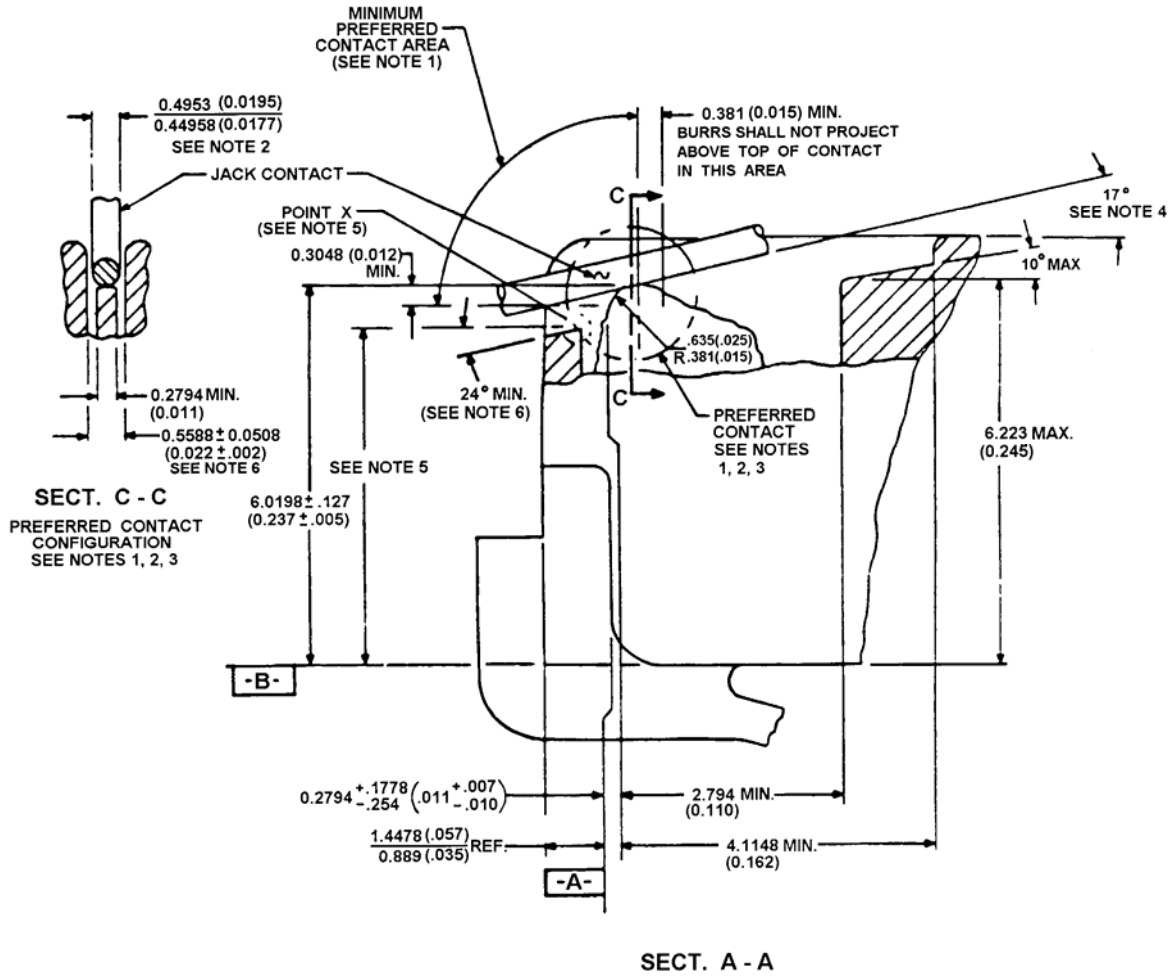

NOTE:- THE 6 POSITION PLUG / JACK CONTACT SPECIFICATION IS IDENTICAL

Figure 4-12: 8-Position Unkeyed Plug, Plug/Jack Contact Specification

**NOTES to Figure 4-12:**

1. The plug/jack contact interface shall be hard gold to hard gold (see 5.1) and shall have a minimum gold thickness of 1.2700  $\mu\text{m}$  (50  $\mu\text{in}$ ) on each side of the interface. Alternative contact material that is compatible with hard gold and provides equivalent contact performance may be used under certain conditions (see 5.2). The minimum contact force at the interface shall be 0.98 N (100 g). A smooth, burr-free surface shall exist at the interface in the area shown. Contact surface roughness shall be 0.8128  $\mu\text{m}$  (32  $\mu\text{in}$ ) maximum. Compliance can be determined by observation with 10X magnification. Compare surface protrusions and burrs on the contact surface with a 32- $\mu\text{in}$ , ground-surface-finish gauge.
2. The jack contact design is based upon 0.4572 mm (0.018 in) spring temper phosphor bronze round wire in the modular plug blade and jack contact interface. Other contact configurations that provide contact performance equal to or better than the preferred configurations and do not cause damage to the plug or jack are permitted. Contact width should be 0.44958/0.49530 mm (0.0177/0.0195 in). Deviations from the desirable jack contact width are permitted for round contacts as well as noncircular cross sectional shapes but they shall be compatible with existing plug configurations. The requirements of Note 1 to Figure 4-12 shall apply to all possible contract areas.
3. The configuration of the plug contact and the front plastic of the plug shall prevent jack contacts from being damaged during plug insertion into jacks.
4. This nominal contact angle should be provided between plugs and jacks with the plug latched into the jack. This angle shall be equal to or less than 24° to avoid loss of electrical contact between the plug and jack. The nominal contact angle shall be equal to or greater than 13° to prevent interference between jack contacts and the internal plastic in the plug.
5. To avoid loss of electrical contact, the dimension from datum B to the highest point "X" should be 5.0800 mm (0.200 in) max. A dimension greater than 5.3594 mm (0.211 in) could result in loss of electrical contact between plugs and jacks. The 5.3594 mm (0.211 in) max. shall be considered an absolute maximum.
6. The 24° min. angle shall apply only to plugs with front plastic walls higher than 4.8260 mm (0.190 in).

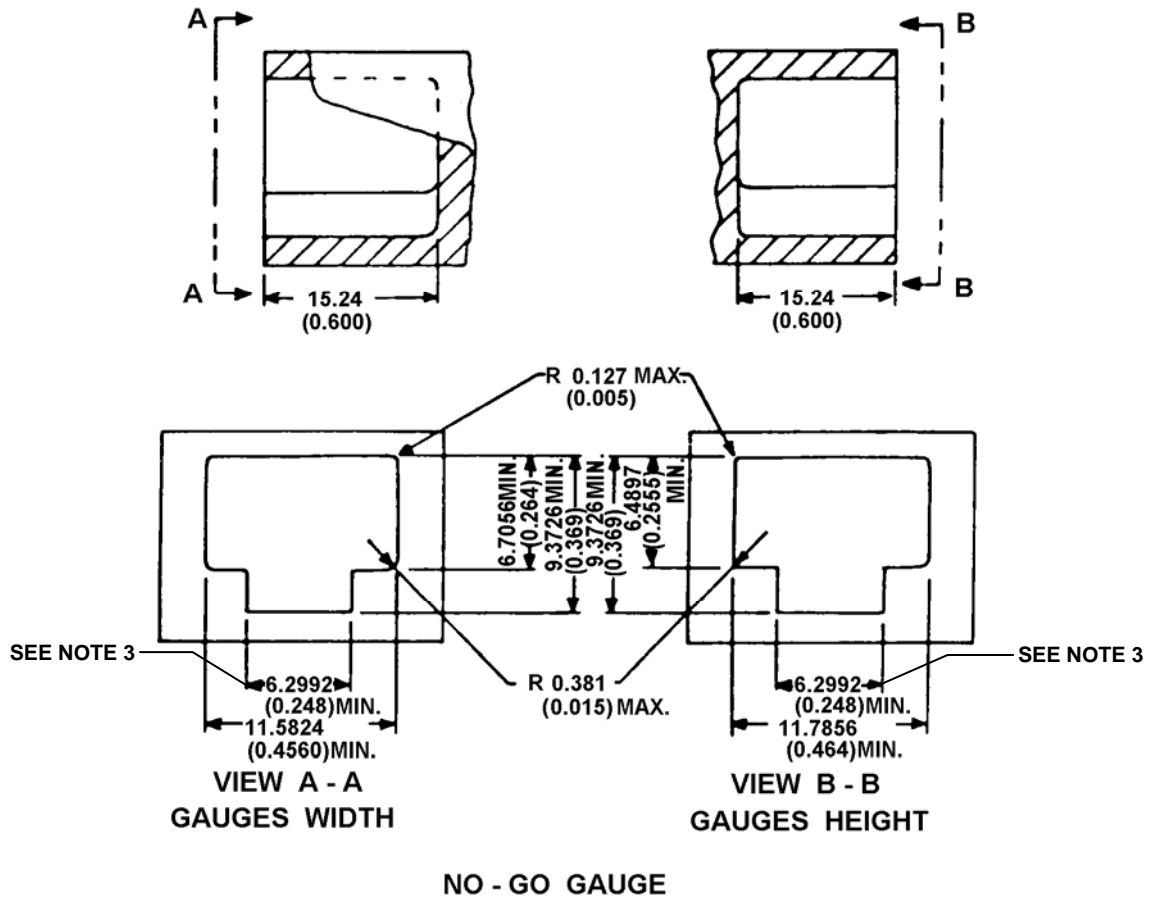

**Figure 4-13: 8-Position Unkeyed Plug, Minimum Plug Size**

**NOTES to Figure 4-13:**

1. The plug shall not be capable of entering the gauge more than 1.778 mm (0.070 in) beyond datum-a- -A- (see Figure 4-10) with 8.90 N (2.0 pounds) insertion force.
2. Dimensions not labelled as minimum or maximum shall be within  $\pm 0.0508$  mm ( $\pm 0.002$  in).
3. 6.2992 mm (0.248 in) dimension shall be centrally located with respect to 11.7856 mm (0.464 in) minimum and 11.58240 mm (0.4560 in) minimum dimensions within  $\pm 0.0508$  mm ( $\pm 0.002$  in).

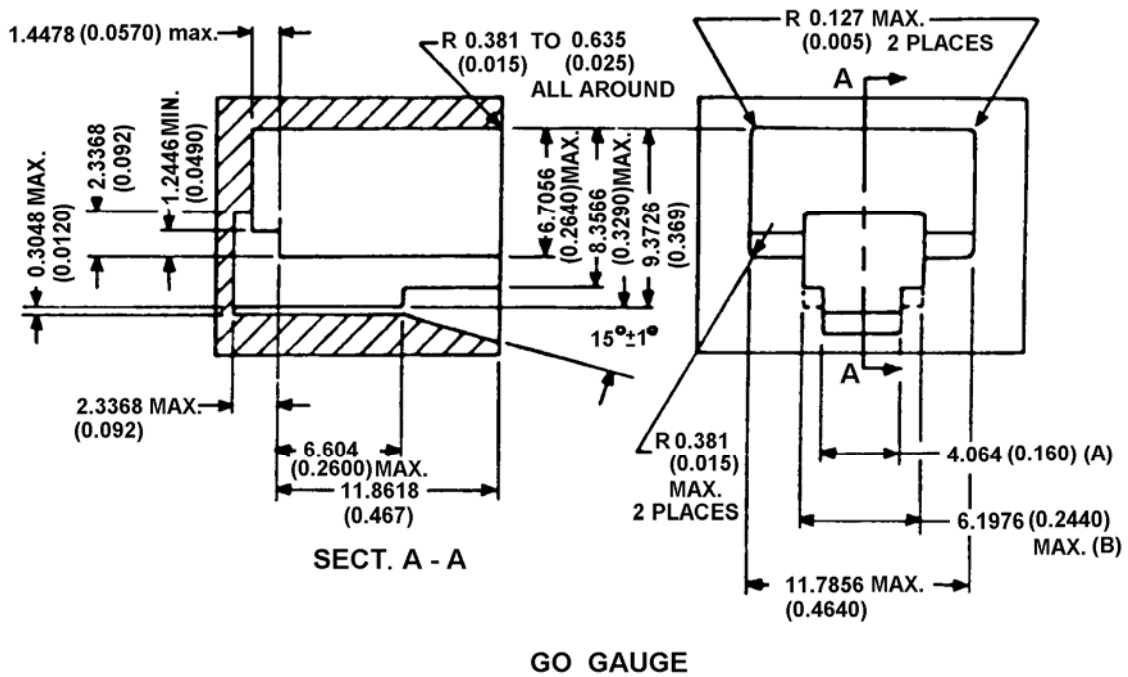

**Figure 4-14: 8-Position Unkeyed Plug, Maximum Plug Size**

**NOTES to Figure 4-14:**

1. The plug shall be capable of insertion and latching into the gauge with 22.24 N (5 pounds) or less insertion force. Plug latching bar shall be depressed so as not to interfere with the plug entry. After insertion and latching, plug shall be capable of removal, with the latch depressed, with a removal force of 44.48 N (10 pounds) or less applied at an advantageous angle.
2. Dimensions not labelled as minimum or maximum shall be within  $\pm 0.0508$  mm (0.002).
3. Dimensions (A) and (B) shall be centrally located with respect to 11.78560 mm (0.4640 in) max. Jack opening width within  $\pm 0.0254$  mm (0.001 in).

### 4.3.4 Miniature 8-Position Series Jack

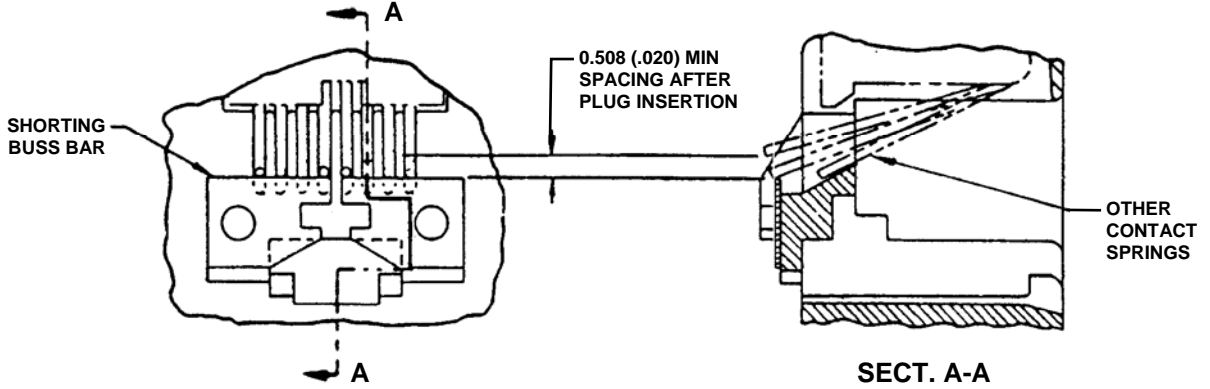

Figure 4-15: 8-Position Series Jack, Contact Specification

NOTE: THIS JACK IS DEPICTED WITH 8 CONTACTS. IT MAY BE FABRICATED WITH LESS THAN 8 CONTACTS.

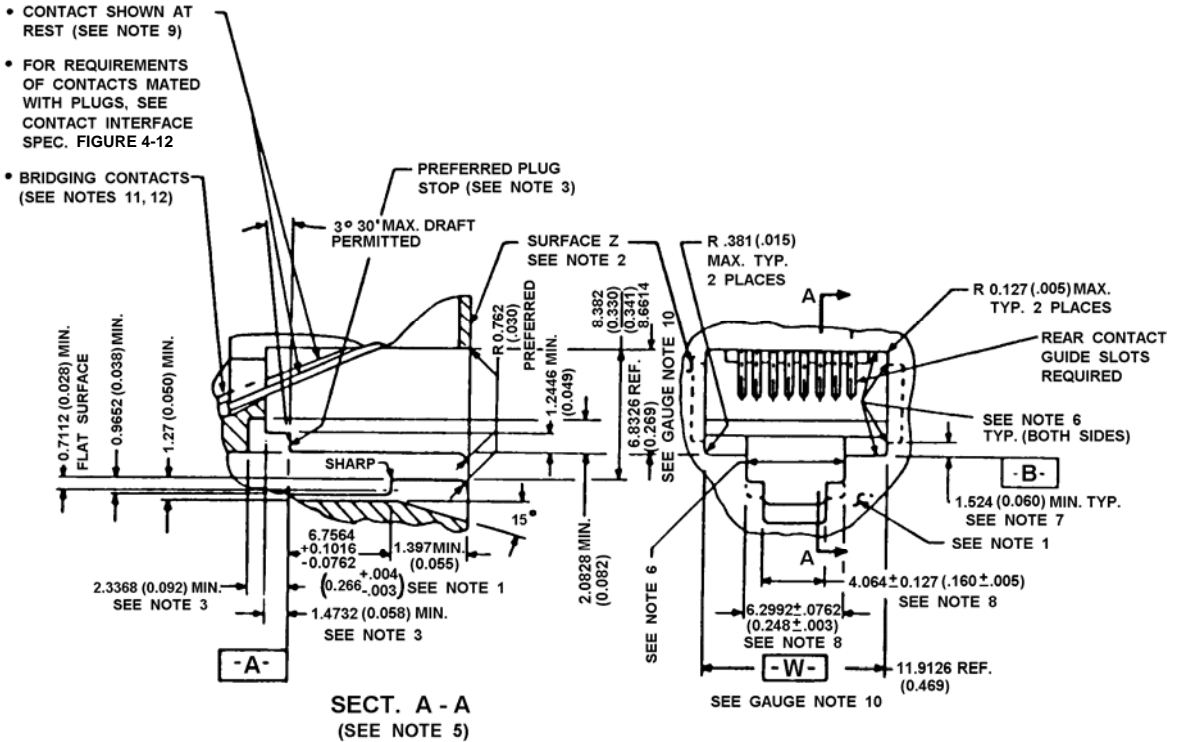
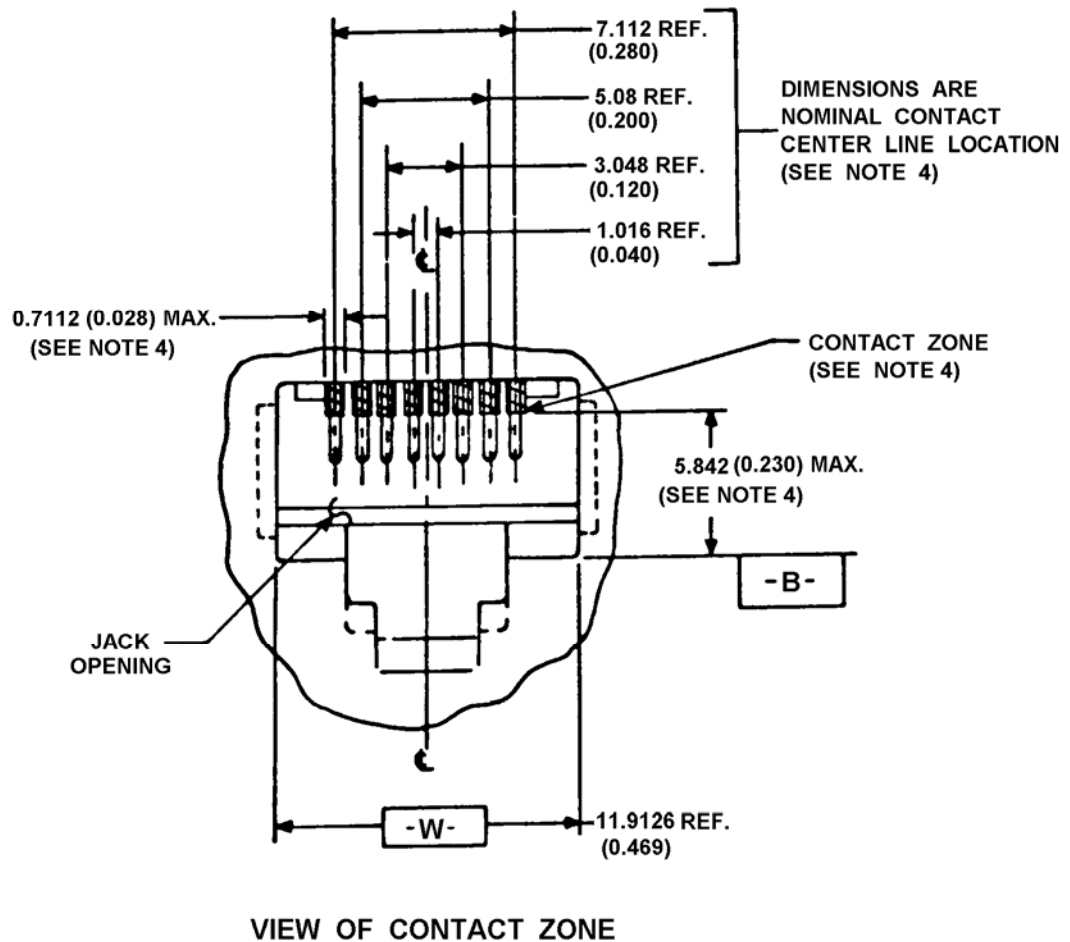

Figure 4-16: 8-Position Series Jack, Mechanical Specification



**Figure 4-17: 8-Position Series Jack, Mechanical Specification (continued)**

**NOTES to Figures 4-16 and 4-17:**

1. Front surface projections beyond the 1.3970 mm (0.055 in) minimum shall be configured so as not to prevent finger access to the plug release catch (Reference Figures 4-2 and 4-10, 6 and 8-Position Plug, Mechanical Specifications). A catch length greater than 1.3970 mm (0.055 in) should be provided for greater breakout strength and improved guidance when interfacing with a 6-position plug.
2. Surface Z need not be planar or coincident with the surface under the plug release catch. Surface Z projections shall not prevent insertion, latching, and unlatching of the standard 8-position plug of 4.3.3.
3. The indicated plug stop surface should be provided. If some other internal feature is used as a plug stop, it shall be located so that the axial movement of a latched plug is no greater than 1.1430 mm (0.045 in).



4. To prevent mistargeting between the plug and jack contacts, the jack contacts shall be completely contained in their individual contact zones, (0.7112 mm (0.028 in) max. wide), where they extend into the jack openings. There is no location requirement for jack contacts below these zones (5.8420 mm (0.230 in) max.), but adequate contact separation shall be maintained to prevent electrical breakdown. These shaded contact zones shall be centrally located, (include all locating tolerances), about the jack opening width 11.9126 mm (0.469 in) Ref, (Datum -W-). Contacts located outside of these zones could result in mistargeting between the jack and plug contacts.
5. All inside and outside corners in the plug cavity shall be 0.3810 mm (0.015 in) radius max. unless specified.
6. These surfaces shall have 0°15' maximum draft.
7. Relief inside the dotted areas on both sides of the jack opening is permitted. The 6.8326 mm (0.269 in) Ref and 11.9126 mm (0.469 in) Ref Gauge Requirements shall be maintained in each of the corners indicated, (Ref. 1.5240 mm (0.060 in) min), to assure proper plug/jack interface guidance.
8. 4.0640 mm (0.160 in) and 6.2992 mm (0.248 in) dimensions shall be centrally located to jack opening width -W- within  $\pm 0.1270$  mm (0.005 in).
9. The contact lengths shall be such that the contacts will always be contained inside the guide slots, and the contacts shall move freely in the slots so as not to restrain plug insertion or damage jack contacts.
10. Gauge Requirements:
  - a. GO: The jack shall be capable of accepting an 11.7856 mm x 6.7056 mm (0.4640 in x 0.2640 in) gauge and the gauge shall be capable of being removed with a maximum force of 8.9 N (2.0 pounds).
  - b. NO GO: The jack shall not accept either a 12.0396 mm x 6.4516 mm (0.4740 in x 0.254 in) horizontal width of opening gauge or a 6.9596 mm x 11.5824 mm (0.2740 in x 0.456 in) vertical height of opening gauge. However, if the gauge is accepted, the force necessary to remove the gauge shall be a minimum of 0.83 N (3.0 ounces).
  - c. Removal force requirements do not include forces contributed by contact springs nor shall external forces be applied to the jack that will affect these removal forces.
  - d. Gauges shall have a 0.7620 mm (0.030 in) radius on the nose and a 0.3810 mm (0.015 in) radius on all edges with clearance provided for contacts.
11. With no plug inserted, conductors 1 and 4 shall be bridged as well as conductors 5 and 8. With a miniature 8-position plug inserted into the jack, the bridge connectors shall be broken and a series connection shall be made in both sides of the line. With a 6-position plug inserted, the bridged connections shall remain unbroken.
12. The jack contact/bridging interface shall be hard gold to hard gold (see 5.1) and shall have a minimum gold thickness of 1.2700  $\mu\text{m}$  (50  $\mu\text{in}$ ) on each side of the interface. Alternative contact material that is compatible with hard gold and provides equivalent contact performance may be used under certain conditions (see 5.2). The minimum hard gold contact bridging force shall be 0.294 N (30 g).

### 4.3.5 50-Position Miniature Ribbon Plug

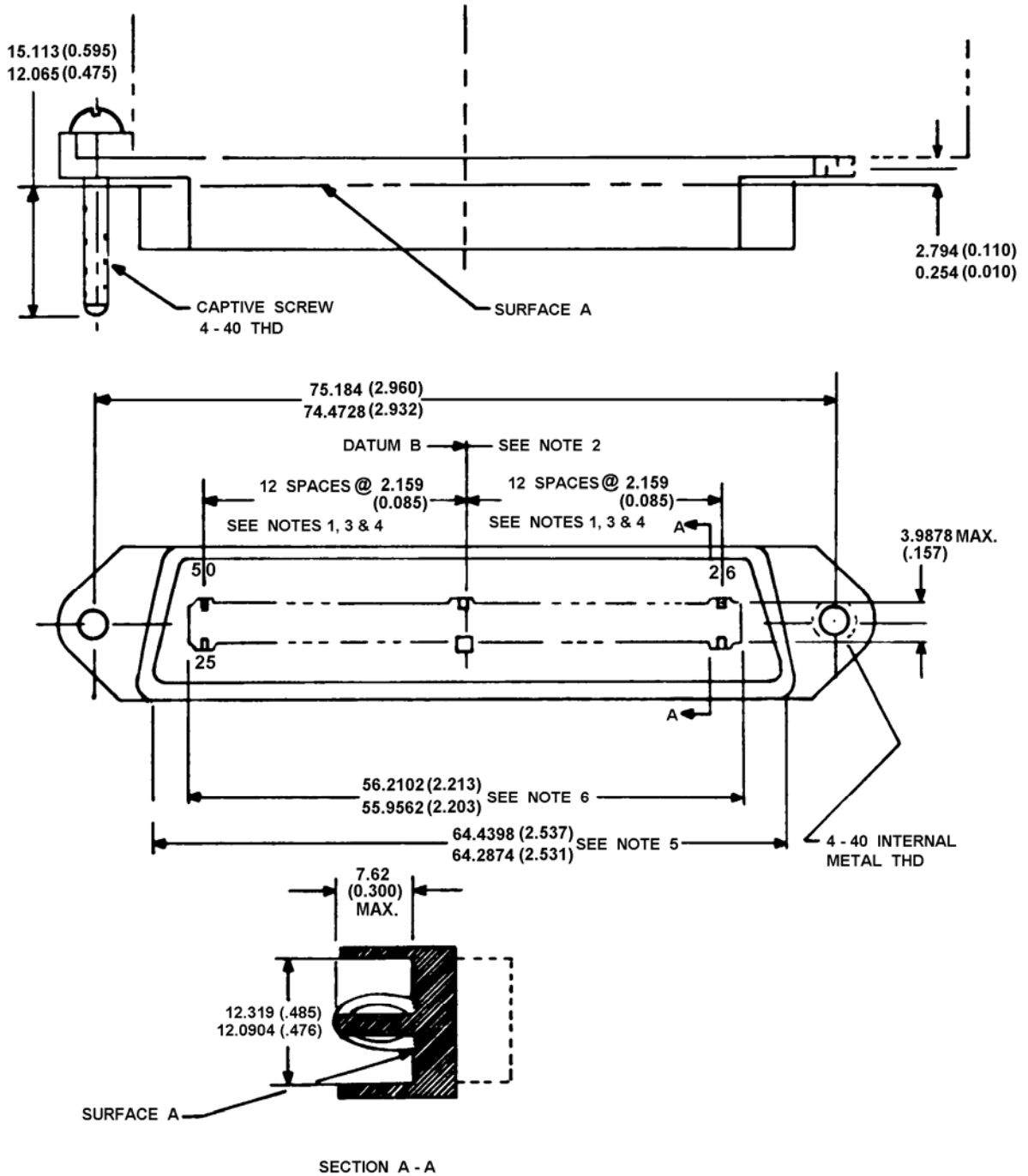

Figure 4-18: 50-Position Miniature Ribbon Plug

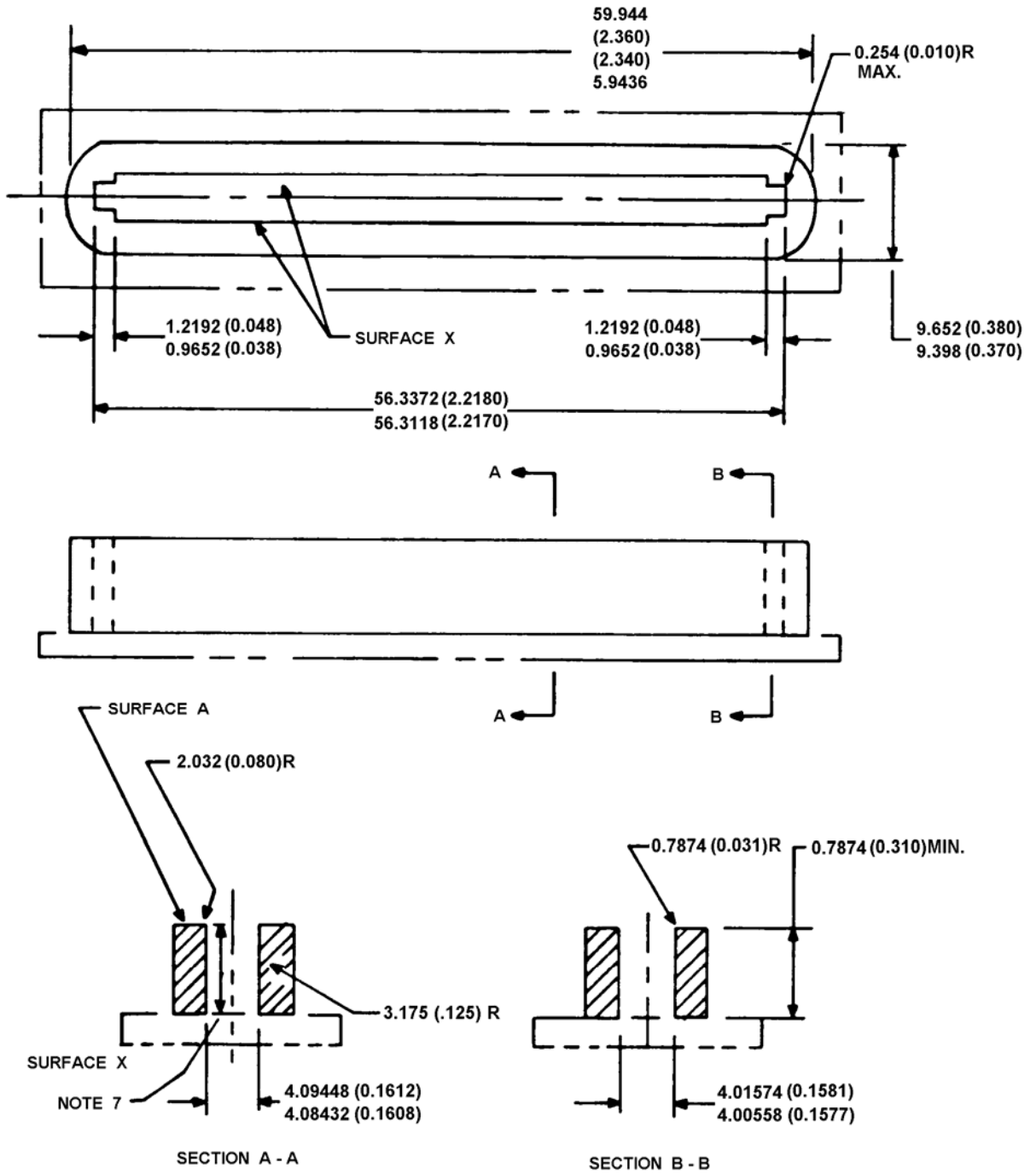

Figure 4-19: 50-Position Miniature Ribbon Plug Sizing Gauge

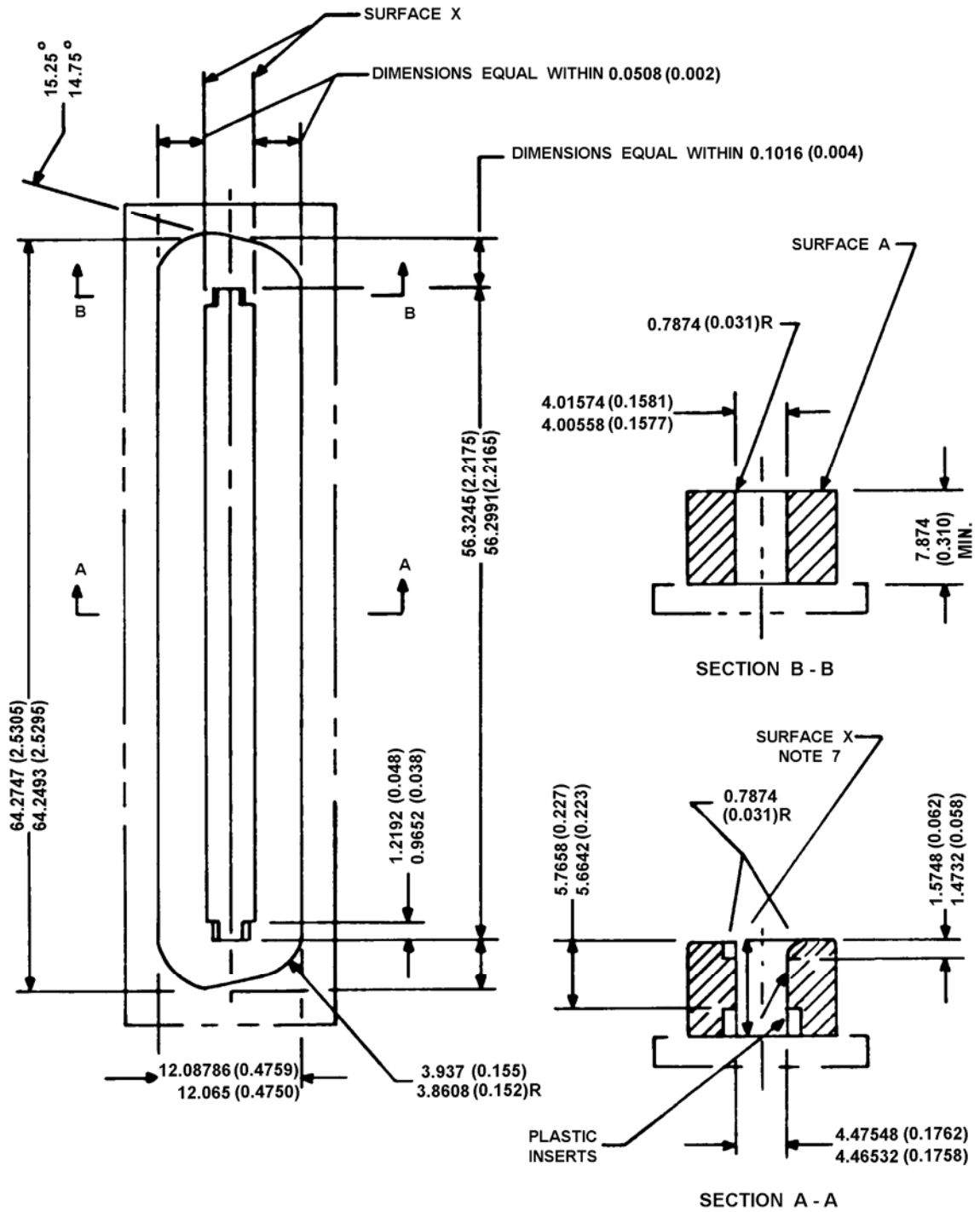

Figure 4-20: 50-Position Miniature Ribbon Plug Continuity Gauge

**NOTES to Figures 4-18, 4-19 and 4-20:**

1. Contact finish in the region of contact shall be gold,  $0.7620\ \mu\text{m}$  ( $30\ \mu\text{in}$ ) minimum thickness, and should be electrodeposited hard gold.
2. "Datum B" shall be the center line of contact cavities.
3. The center line of each contact shall be located within  $0.2286\ \text{mm}$  ( $0.009\ \text{in}$ ) of true position with respect to "Datum B".
4. Contact width at region of contact shall be  $(1.143 \pm 0.0508)\ \text{mm}$  ( $0.04 \pm 0.002\ \text{in}$ ).
5. Center line of shell dimension indicated shall be within  $0.1270\ \text{mm}$  ( $0.005\ \text{in}$ ) of "Datum B".
6. Center line of barrier dimension indicated shall be within  $0.1270\ \text{mm}$  ( $0.005\ \text{in}$ ) of "Datum B".
7. "Surface X" shall have a  $0.1016\ \mu\text{m}$  ( $4\ \mu\text{in}$ ) finish or better; finishing shall be done in the direction of the arrow.
8. A force of not more than  $178\ \text{N}$  ( $40\ \text{pounds}$ ) shall be sufficient to fully insert the plug onto the sizing gauge shown on Figure 4-18. The plug is fully inserted when "Surface A" of the plug touches "Surface A" of the sizing gauge.
9. After one insertion of the plug on the sizing gauge, Figure 4-19, a force of not more than  $44.5\ \text{N}$  ( $10\ \text{pounds}$ ) shall be sufficient to fully insert the plug on the continuity gauge shown in Figure 4-20. The plug is fully inserted on the continuity gauge when "Surface A" of the plug touches "Surface A" of the continuity gauge.
10. When the plug is fully inserted on the continuity gauge, Figure 4-20, after having been inserted once on the sizing gauge, Figure 4-19, all contacts of the plug shall electrically contact the continuity gauge as determined by an electrical continuity test which applies an open circuit voltage of not more than  $10\ \text{Volts}$ . Results greater than  $200\ \Omega$  indicate test failure.

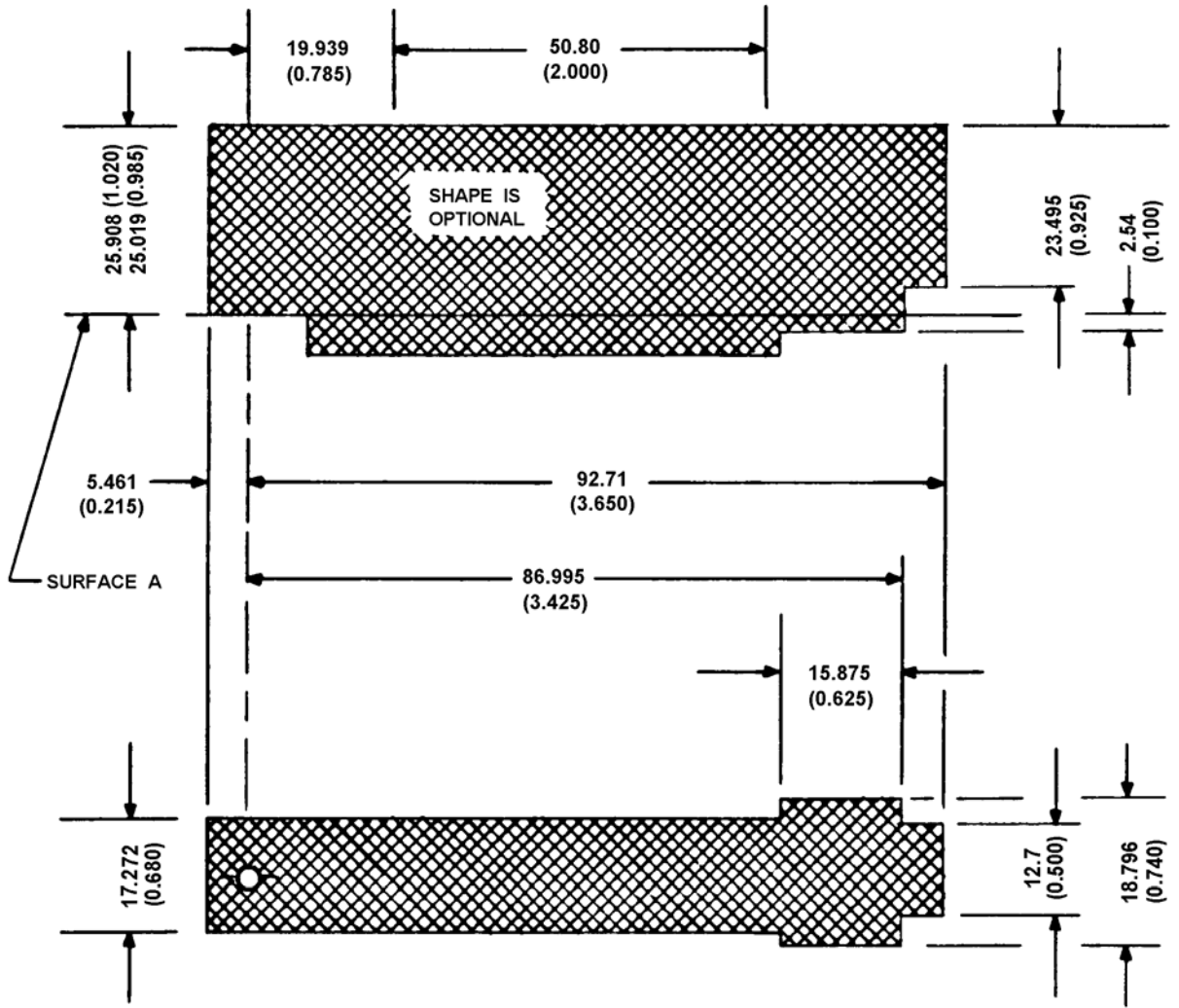

Figure 4-21: 50-Position Miniature Ribbon Plug Hood Envelope

4.3.6 50-Position Miniature Ribbon Jack

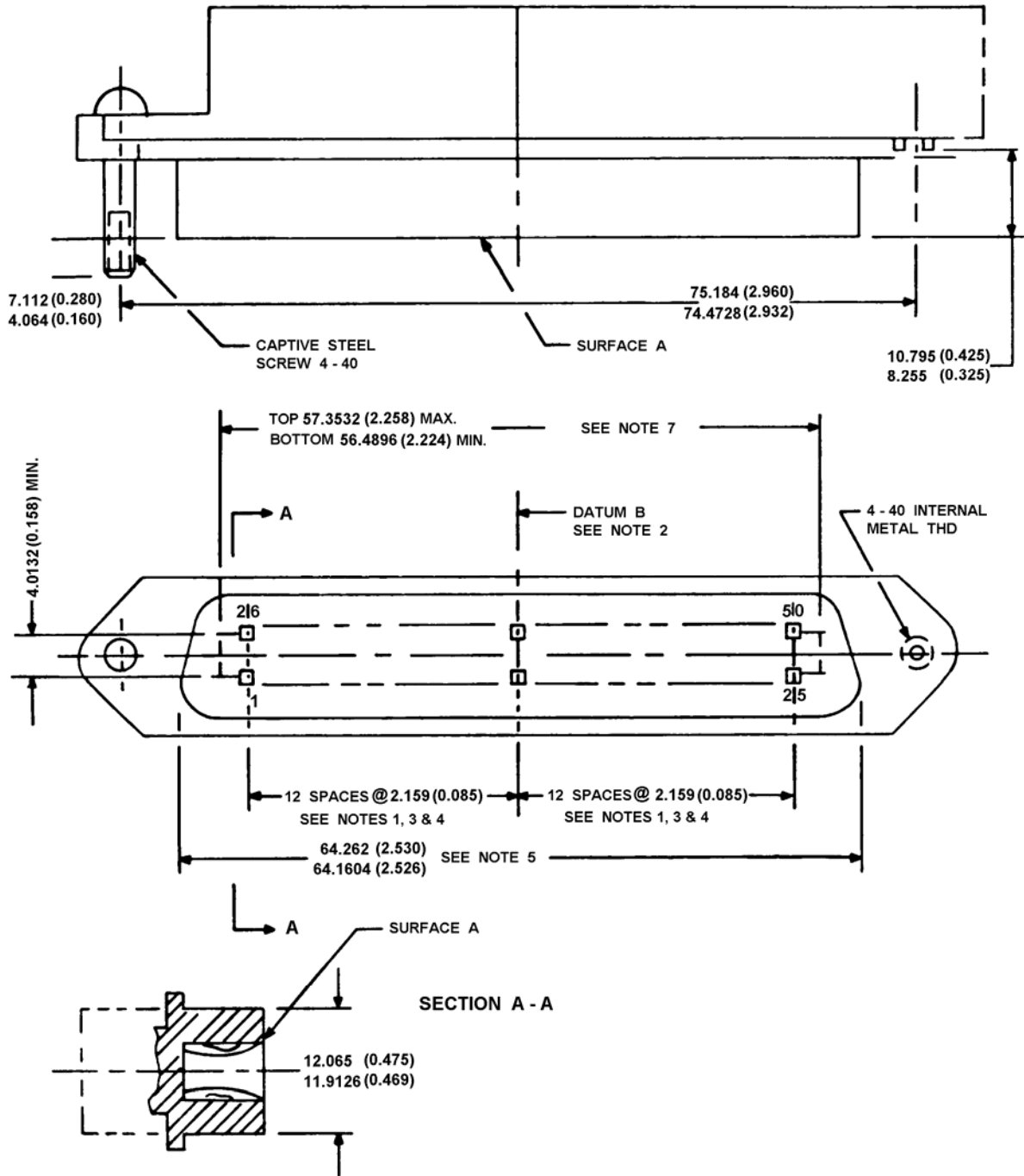

Figure 4-22: 50-Position Miniature Ribbon Jack

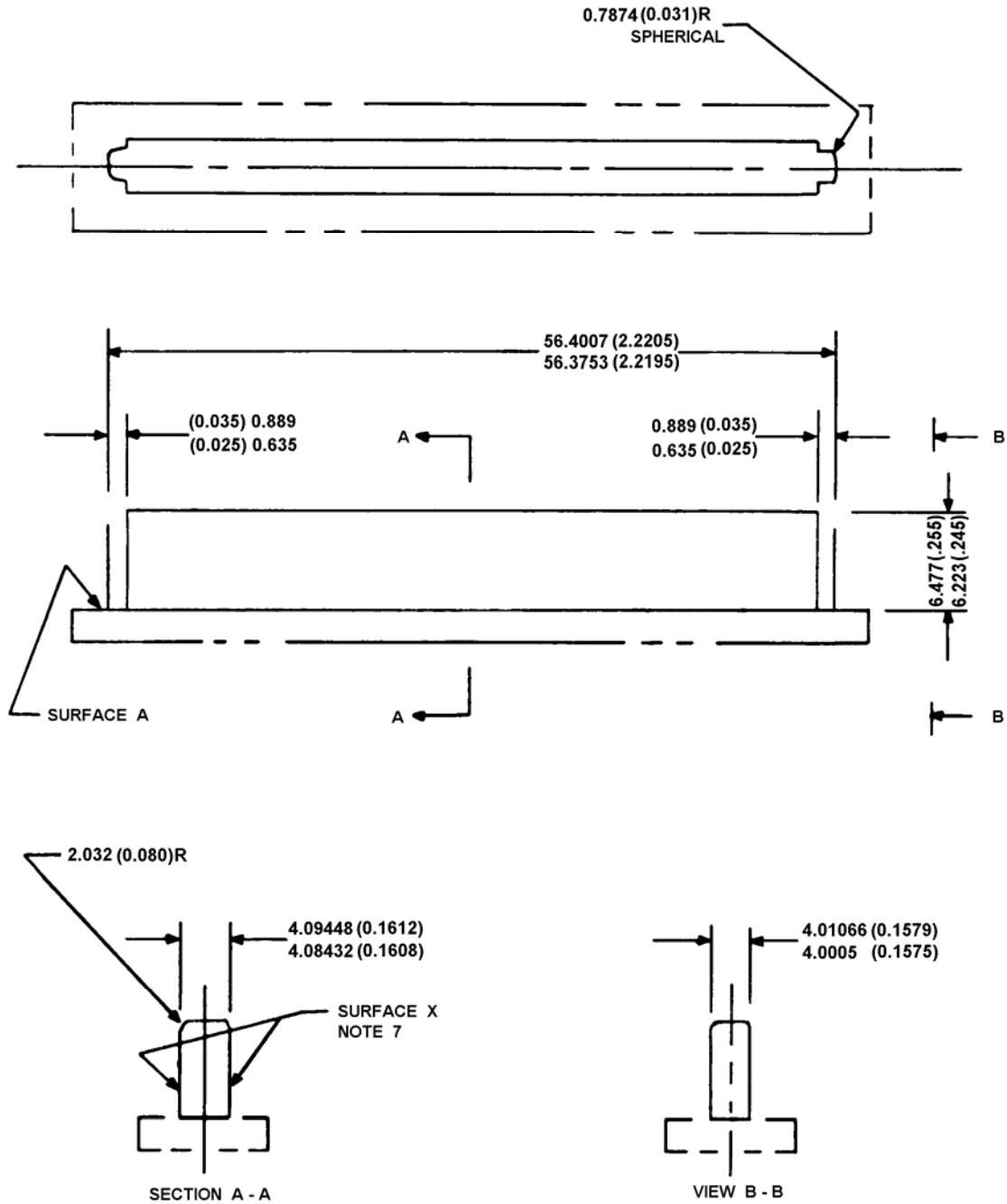

Figure 4-23: 50-Position Miniature Ribbon Jack Sizing Gauge



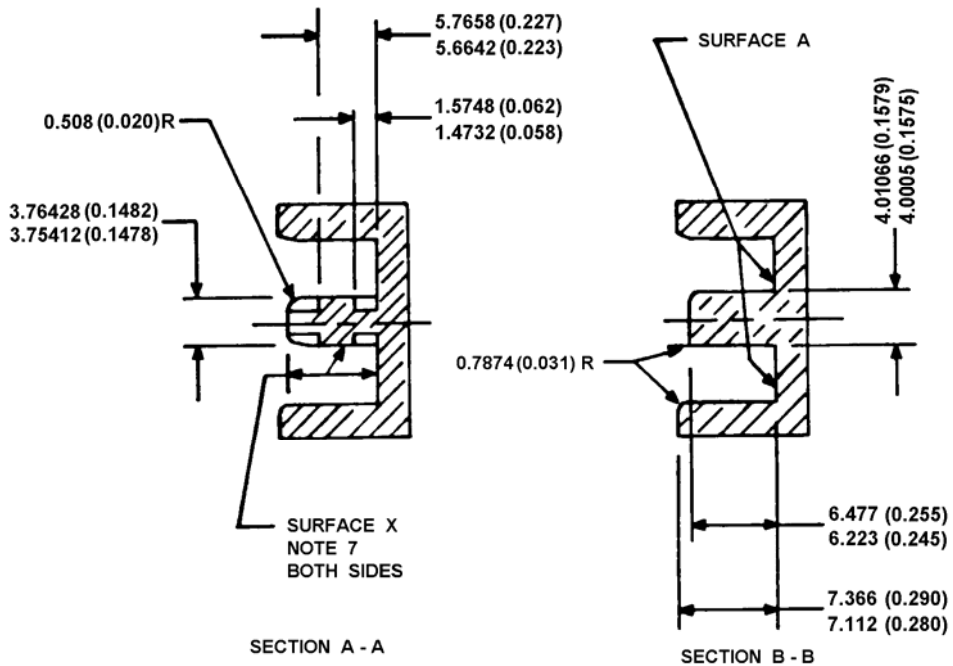
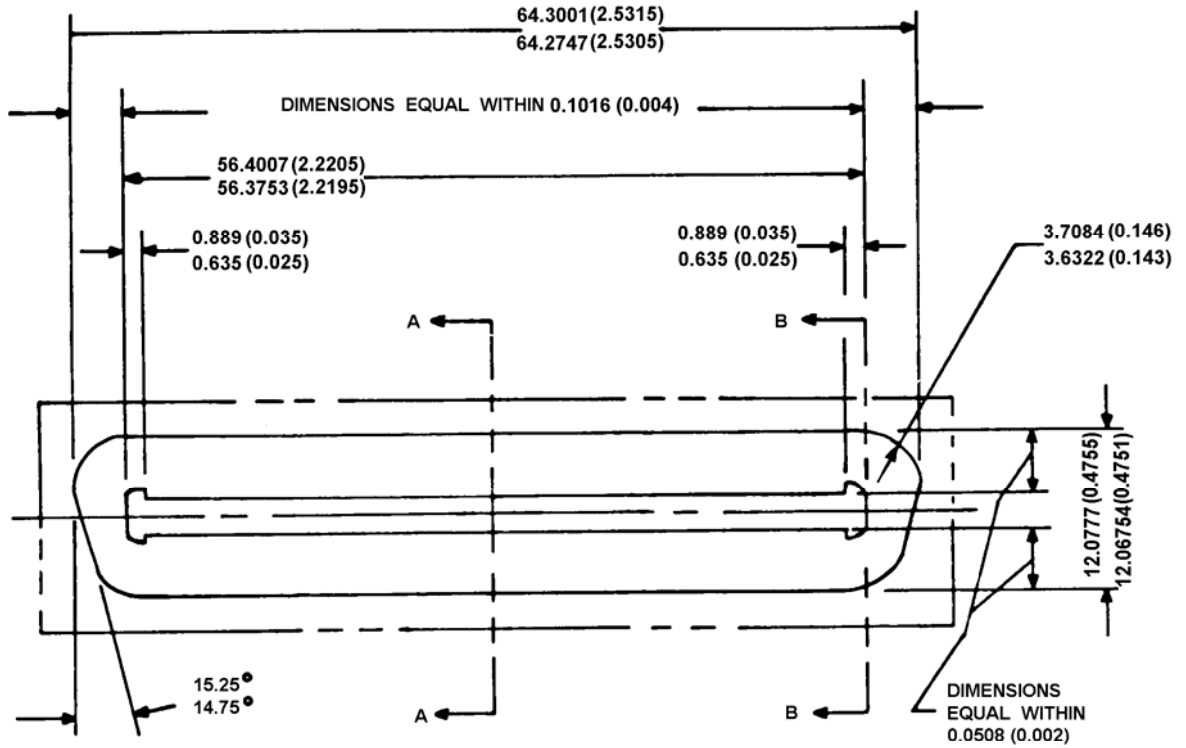

Figure 4-24: 50-Position Miniature Ribbon Jack Continuity Gauge

**NOTES to Figures 4-22, 4-23 and 4-24:**

1. Contact finish in the region of contact shall be gold,  $0.7620\ \mu\text{m}$  ( $30\ \mu\text{in}$ ) minimum thickness, and should be electrodeposited hard gold.
2. "Datum B" shall be considered the center line of contact cavities.
3. The center line of each contact shall be located within  $0.2286\ \text{mm}$  ( $0.009\ \text{in}$ ) of true position with respect to "Datum B".
4. Contact width at region of contact shall be  $1.1430 \pm 0.0508\ \text{mm}$  ( $0.045 \pm 0.002\ \text{in}$ ).
5. Center line of shell dimension indicated shall be within  $0.1270\ \text{mm}$  ( $0.005\ \text{in}$ ) of Datum B".
6. Center line of cavity dimension indicated shall be within  $0.1270\ \text{mm}$  ( $0.005\ \text{in}$ ) of Datum B".
7. "Surface X" shall have a  $0.1016\ \mu\text{m}$  ( $4\ \mu\text{in}$ ) finish or better; finishing shall be done in the direction of the arrow.
8. A force of not more than  $134\ \text{N}$  (30 pounds) shall be sufficient to fully insert the jack onto the sizing gauge shown on Figure 4-23. The jack is fully inserted when "Surface A" of the jack touches "Surface A" of the sizing gauge.
9. After one insertion of the jack on the sizing gauge, Figure 4-23, a force of not more than  $44.5\ \text{N}$  (10 pounds) shall be sufficient to fully insert the jack on the continuity gauge shown in Figure 4-24. The jack is fully inserted on the continuity gauge when "Surface A" of the jack touches "Surface A" of the continuity gauge.
10. When the jack is fully inserted on the continuity gauge, Figure 4-24, after having been inserted once on the sizing gauge, all contacts of the jack shall electrically contact the continuity gauge as determined by an electrical continuity test which applies an open circuit voltage of not more than 10 volts. Results greater than  $200\ \Omega$  indicate test failure.

### 4.3.7 3-Position Weatherproof Plug

Contact blade material shall be brass, with minimum 7.62 μm (300 μin) thick nickel plating.

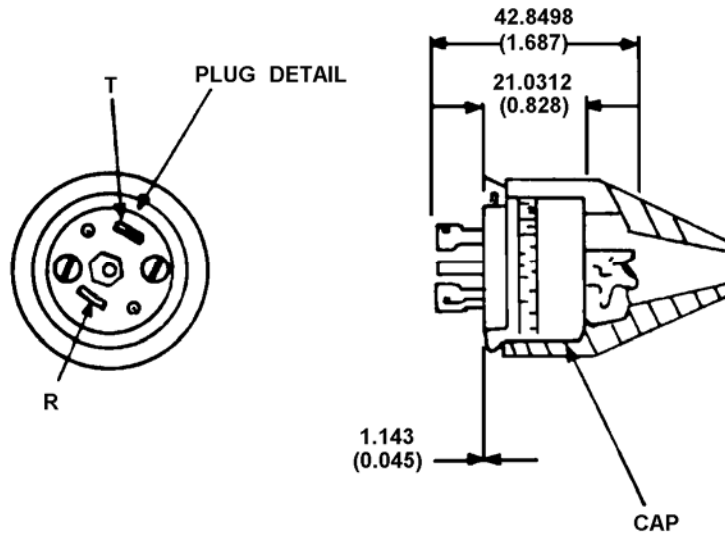

Figure 4-25: 3-Position Plug, Plug Assembly

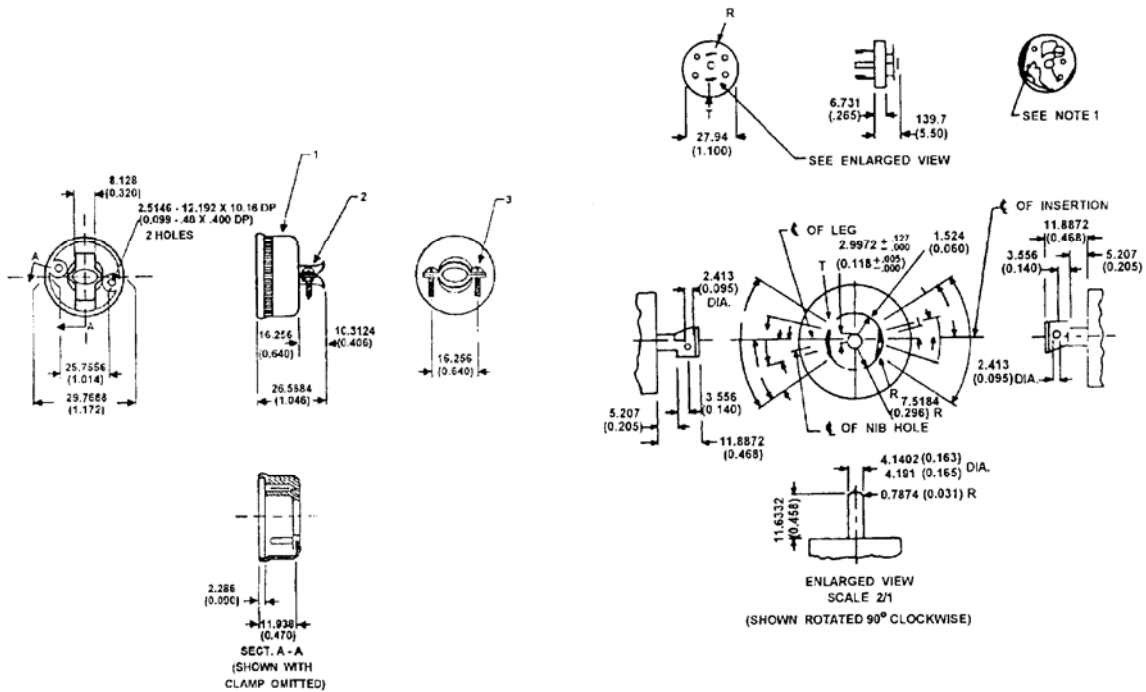
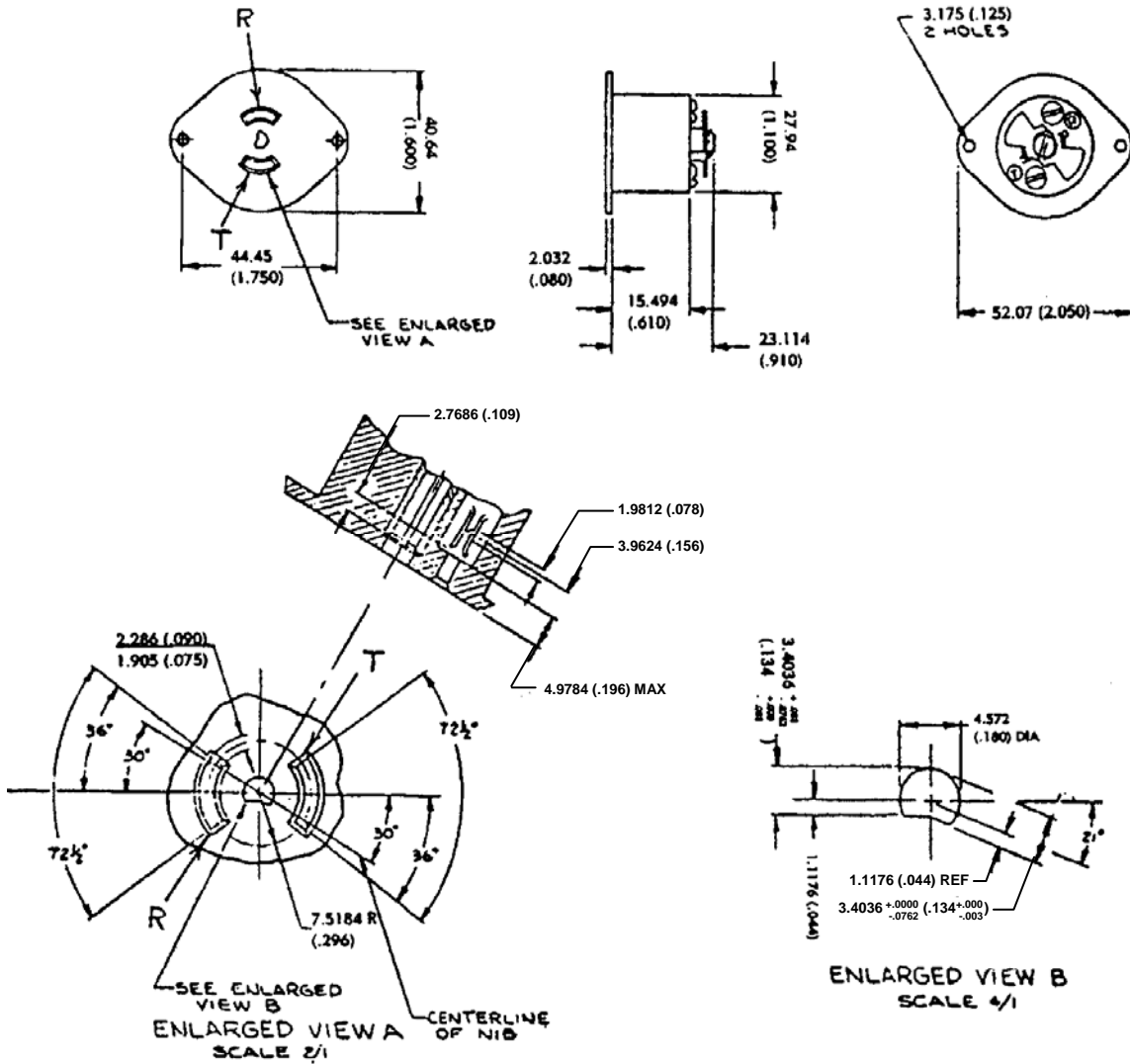

Figure 4-26: 3-Position Plug, Detail

### 4.3.8 3-Position Weatherproof Jack



Contact blade material shall be brass, with minimum 7.62  $\mu\text{m}$  (300  $\mu\text{in}$ ) thick nickel plating.

Figure 4-27: 3-Position Jack, Detail

### 4.3.9 Miniature 8-Position Plug, Keyed

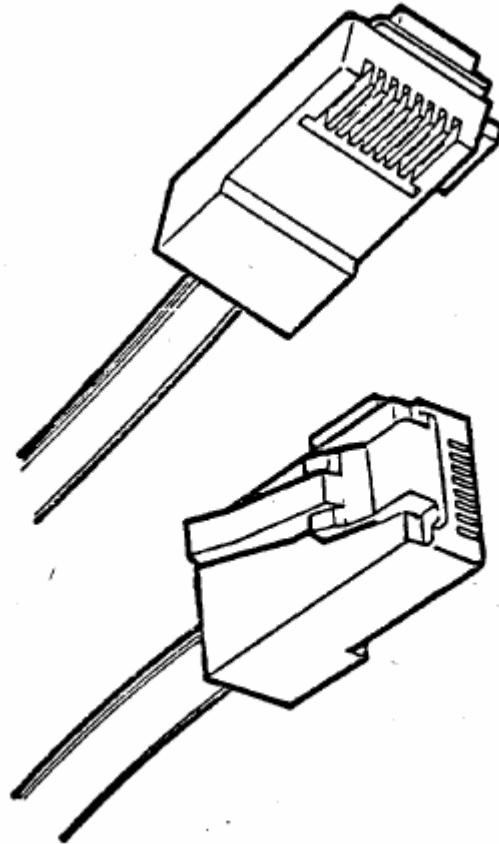

Figure 4-28: View of Miniature 8-Position Plug, Keyed

NOTE: THIS PLUG IS DESIGNED WITH ITS FULL 8 CONTACT CAPACITY. IT MAY BE FABRICATED WITH LESS THAN 8 CONTACTS.

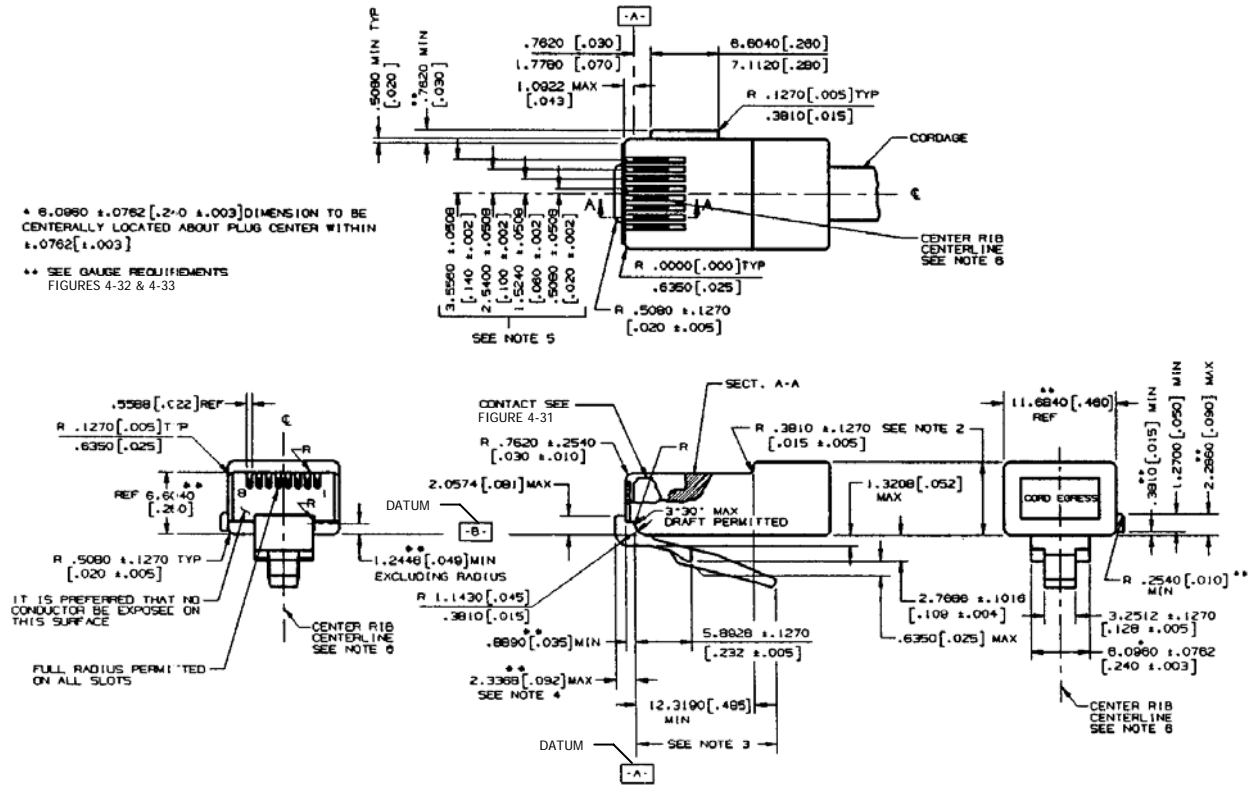

Figure 4-29: 8-Position Keyed Plug, Mechanical Specification

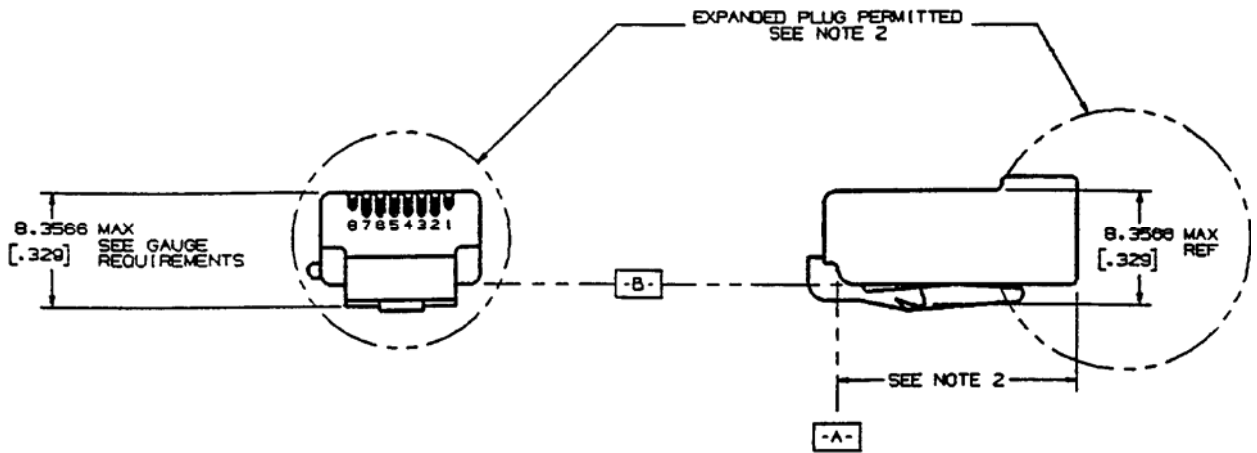
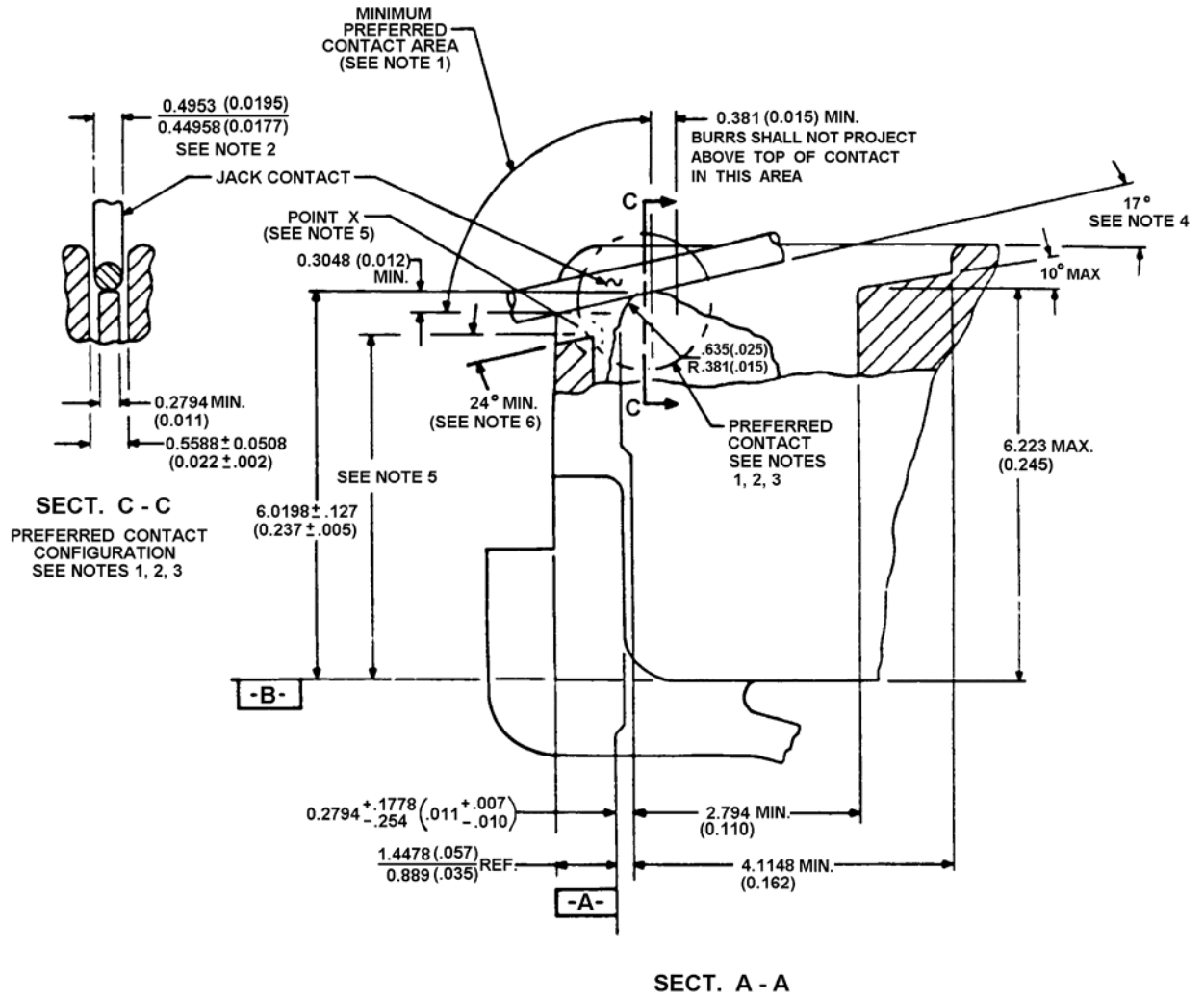

Figure 4-30: 8-Position Keyed Plug, Mechanical Specification (continued)

**NOTES to Figures 4-29 and 4-30:**

1. All plugs shall meet the requirements of the plug go and no-go gauges shown in Figures 4-32 and 4-33.
2. The standard plug height in the area shown shall be 8.0010 mm (0.315 in) maximum. The standard plug length shall be 23.1140 mm (0.910 in) maximum. Plugs may be made longer than standard or adapted for direct use on special cords, adapters without cordage, apparatus or equipment. Plugs longer and/ or higher than standard could inhibit the special features of some network jack enclosures. It is the responsibility of the designers and manufacturers of communication equipment who use such plugs to assure that they are compatible with the hardware used to mount standard jacks with which they plan to interface.
3. The minimum tab length shall be 14.6050 mm (0.575 in). The maximum tab length normally shall be no longer than 15.8750 mm (0.625 in). Longer tabs may be used with the limitations described in Note 2 to Figures 4-29 and 4-30.
4. To obtain maximum plug guidance in jacks, the front plug nose should be extended to the 2.3368 mm (0.092 in) maximum.
5. These dimensions apply to the location of jack contact receiving slots. Plug contacts should be centered axially in these slots.
6. The center rib centerline shall be coincident with the plug width, 11.6840 mm ref (0.460 in ref.) center line within  $\pm 0.0762\text{mm}$  ( $\pm 0.003$  in)



NOTE:- THE 6 POSITION PLUG / JACK CONTACT SPECIFICATION IS IDENTICAL

Figure 4-31: 8-Position Keyed Plug, Plug/Jack Contact Specification



**NOTES to Figure 4-31:**

1. The plug/jack contact interface shall be hard gold to hard gold (see 5.1) and shall have a minimum gold thickness of 1.2700  $\mu\text{m}$  (50  $\mu\text{in}$ ) on each side of the interface. Alternative contact material that is compatible with hard gold and provides equivalent contact performance may be used under certain conditions (see 5.2). The minimum contact force at the interface shall be 0.98 N (100 g). A smooth, burr-free surface shall exist at the inter-face in the area shown. Contact surface roughness shall be 0.8128  $\mu\text{m}$  (32  $\mu\text{in}$ ) maximum. Compliance can be determined by observation with 10X magnification. Compare surface protrusions and burrs on the contact surface with a 32- $\mu\text{in}$ , ground-surface-finish gauge.
2. The jack contact design is based upon 0.4572 mm (0.018 in) spring temper phosphor bronze round wire in the modular plug blade and jack contact interface. Other contact configurations that provide contact performance equal to or better than the preferred configurations and do not cause damage to the plug or jack may be provided. The jack contact width normally shall be 0.44958/0.49530 mm (0.0177/0.0195 in). Deviations from the preferred jack contact width are permitted for round contacts as well as noncircular cross sectional shapes but such deviations shall be compatible with existing plug configurations. The requirements of Note 1 to Figure 4-31 shall apply to all possible contact areas.
3. The configuration of the plug contact and the front plastic of the plug shall prevent jack contacts from being damaged during plug insertion into jacks.
4. This should be the nominal contact angle between plugs and jacks with the plug latched into the jack. This angle shall be equal to or less than  $24^\circ$  to avoid loss of electrical contact between the plug and jack. The nominal contact angle shall be equal to or greater than  $13^\circ$  to avoid interference between jack contacts and the internal plastic in the plug.
5. To avoid loss of electrical contact, the dimension from "Datum B" to the highest point "X" should be 5.0800 mm (0.200 in) max. A dimension greater than 5.3594 mm (0.211 in) could result in loss of electrical contact between plugs and jacks. The 5.3594 mm (0.211 in) max. shall be considered an absolute maximum.
6. The  $25^\circ$  min. angle shall apply only to plugs with front plastic walls higher than 4.8260 mm (0.190 in).

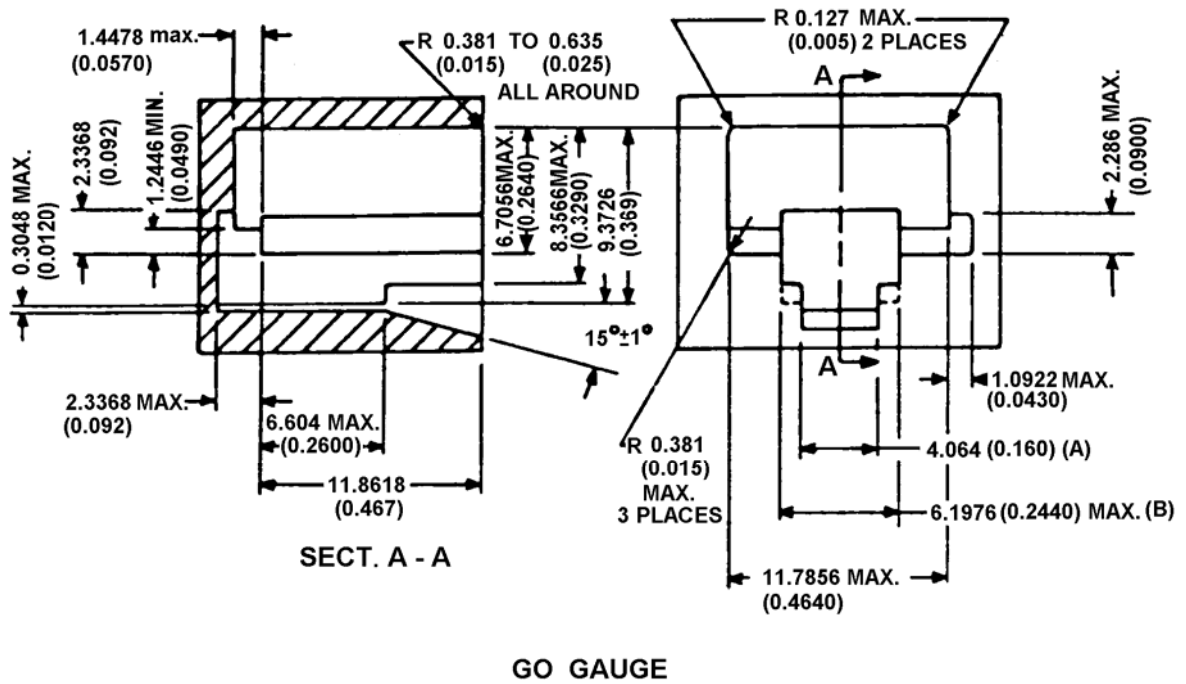

**Figure 4-32: 8-Position Keyed Plug, Maximum Plug Size**

**NOTES TO Figure 4-32:**

1. The plug shall be capable of insertion and latching into the gauge with 22.24 N (5 pounds) or less insertion force. Plug latching bar shall be depressed so as not to interfere with the plug entry. After insertion and latching, plug shall be capable of removal, with the latch depressed, with a removal force of 44.48 N (10 pounds) or less applied at an advantageous angle.
2. Dimensions not labelled as minimum or maximum shall be within  $\pm 0.0508$  mm ( $\pm 0.002$  in).
3. Dimensions (A) and (B) shall be centrally located with respect to 11.7856 mm (0.4640 in) max. Jack opening width shall be within  $\pm 0.0254$  mm ( $\pm 0.001$  in).

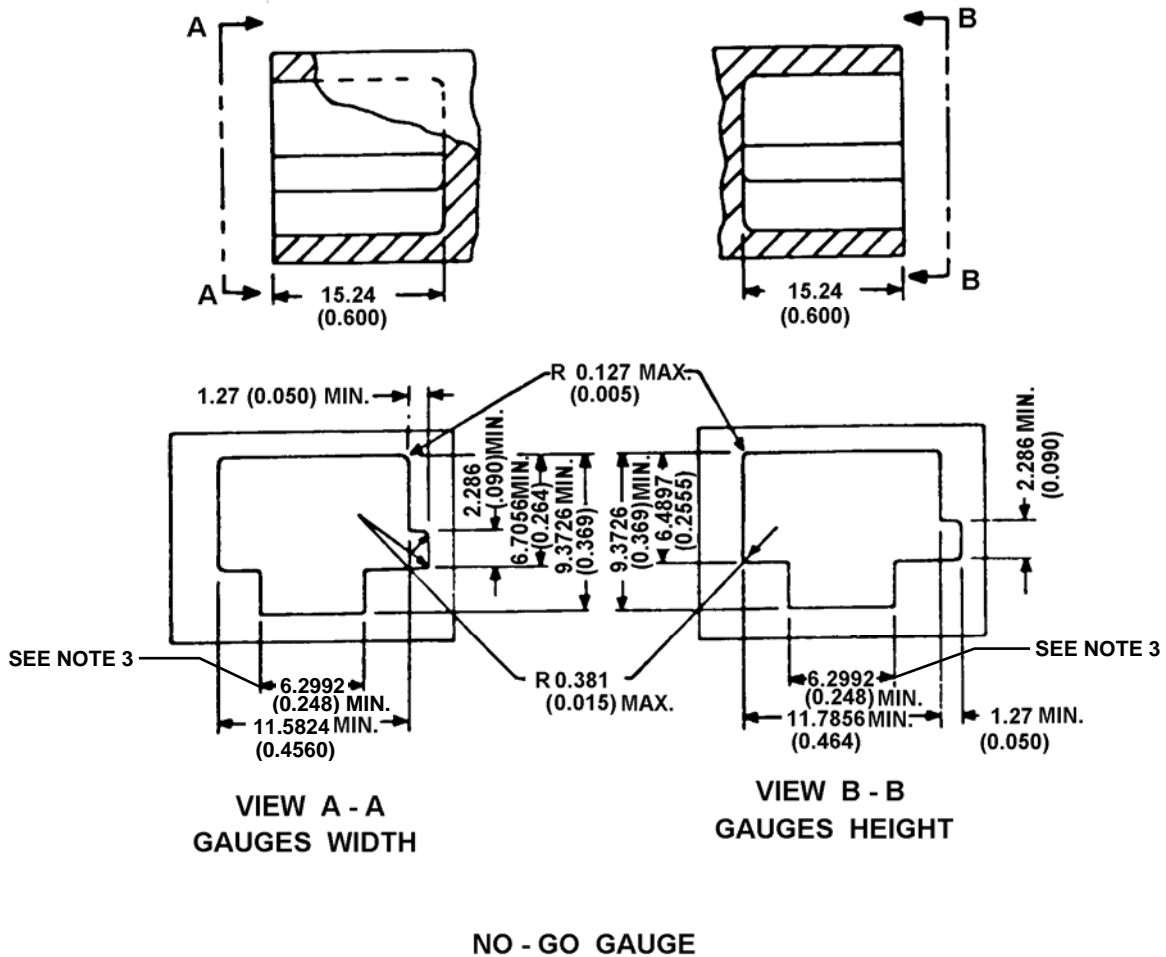

**Figure 4-33: 8-Position Keyed Plug, Minimum Plug Size**

**NOTES to Figure 4-33:**

1. The plug shall not enter the gauge more than 1.778 mm (0.070 in) beyond datum -A- (see Figure 4-29 with 8.90 N (2.0 pounds) insertion force).
2. Dimensions not labelled as minimum or maximum shall be within  $\pm 0.0508$  mm ( $\pm 0.002$ ).
3. 6.2992 mm (0.248 in) dimension shall be centrally located with respect to 11.7856 mm (0.464 in) minimum and 11.5824 mm (0.4560 in) minimum dimensions within  $\pm 0.0508$  mm (0.002 in).

### 4.3.10 Miniature 8-Position Keyed Jack

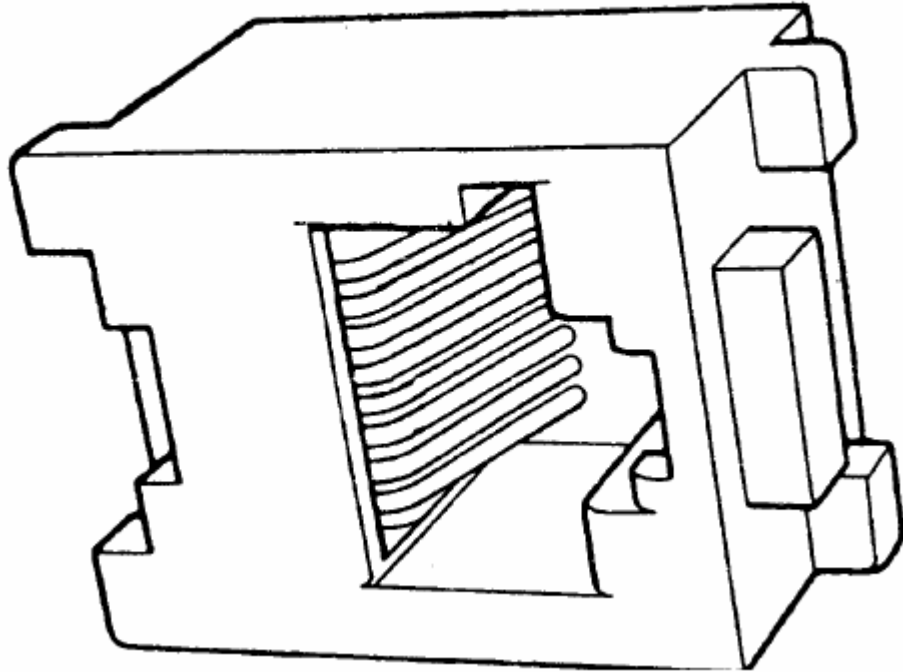

Figure 4-34: View of Miniature 8-Position Keyed Jack

Note :- This jack is depicted with 8 contacts. It may be fabricated with less than 8 contacts.

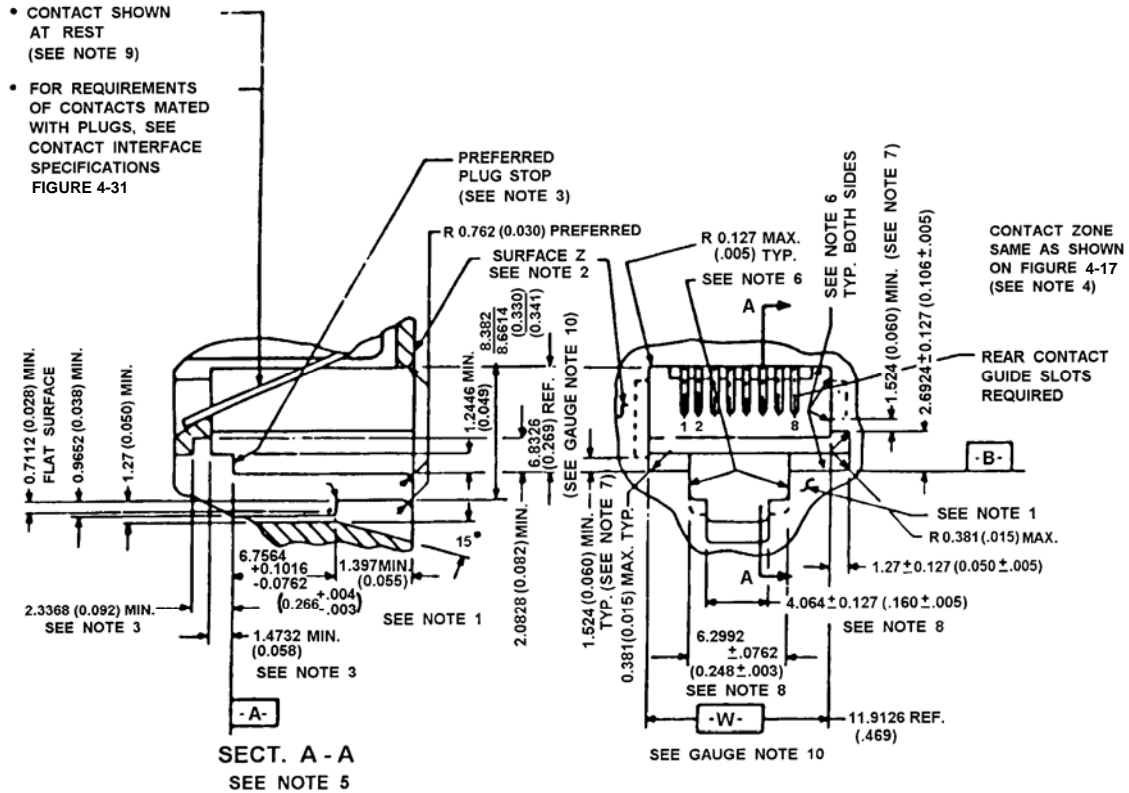

Figure 4-35: 8-Position Keyed Jack, Mechanical Specification

**NOTES to Figure 4-35:**

1. Front surface projections beyond the 1.3970 mm (0.055 in) minimum shall be configured so as not to prevent finger access to the plug release catch (Reference Figure 4-30, 8-Position Plug, Mechanical Specifications). A catch length should be greater than 1.3970 mm (0.055 in) to provide greater breakout strength and improved guidance when interfacing with a 6-position plug.
2. Surface Z need not be planar or coincident with the surface under the plug release catch. Surface Z projections shall not prevent insertion, latching, and unlatching of the keyed 8-position plug of 4.3.9.
3. The indicated plug stop surface should be provided. If some other internal feature is used as a plug stop, it shall be located so that the axial movement of a latched plug is no greater than 1.1430 mm (0.045) in.
4. To prevent mistargeting between the plug and jack contacts, the jack contacts

- shall be completely contained in their individual contact zones 0.7112 mm (0.028 in) max wide, where they extend into the jack openings. There is no location requirement for jack contacts below these zones (5.8420 mm (0.230 in) max), but adequate contact separation shall be maintained to prevent electrical breakdown. These shaded contact zones shall be centrally located, (include all locating tolerances), about the jack opening width 11.9126 mm (0.469 in) Ref, (Datum–W–). Contacts located outside of these zones could result in mistargeting between the jack and plug contacts.
5. All inside and outside corners in the plug cavity shall be 0.3810 mm (0.015 in) radius max unless specified.
  6. These surfaces shall have 0°15' maximum draft.
  7. Relief inside the dotted areas on both sides of the jack opening shall be permitted. The 6.8326 mm (0.269 in) Ref and 11.9126 mm (0.469 in) Ref Gauge Requirements shall be maintained in each of the corners indicated, (Ref. 1.5240 mm (0.060 in) min), to assure proper plug/jack interface guidance.
  8. 4.0640 mm (0.160 in) and 6.2992 mm (0.248 in) dimensions shall be centrally located to jack opening width –W– within  $\pm 0.1270$  mm ( $\pm 0.005$  in).
  9. The contact lengths shall be such that the contacts will always be contained inside the guide slots and the contacts shall move freely in the slots so as not to restrain plug insertion or damage jack contacts.
  10. Gauge Requirements:
    - a. GO: The jack shall be capable of accepting an 11.78560 x 6.70560 mm (0.4640 x 0.2640 in) gauge and the gauge shall be capable of being removed with a maximum force of 8.9 N (2.0 pounds).
    - b. NO GO: The jack shall not accept either a 12.03960 x 6.4516 mm (0.4740 x 0.254 in) horizontal width of opening gauge or a 6.95960 x 11.5824 mm (0.2740 x 0.456 in) vertical height of opening gauge. However, if the gauge is accepted, the force necessary to remove the gauge shall be a minimum of 0.83 N (3.0 ounces).
    - c. Removal forces shall not include forces contributed by contact springs nor shall external forces be applied to the jack that will affect these removal forces.
    - d. Gauges shall have a 0.7620 mm (0.030 in) radius on the nose and a 0.3810 mm (0.015 in) radius on all edges with clearance provided for contracts.

## 5 CONTACT REQUIREMENTS

### 5.1 HARD GOLD CONTACTS

Note: The hard gold contact requirements in this clause are not intended to limit the contact interface to one that is produced by a plating process.

#### 5.1.1 Gold Surface Layer

The gold surface layer in the specified contact interface area shall meet the following requirements:

1. The material content shall be 99% pure gold minimum.
2. The material density shall be 17 grams/cm<sup>3</sup> minimum.
3. The minimum gold thickness in the specified interface area shall be
  - a. 1.2700 µm (50 µin) for 6 and 8 position connectors, or
  - b. 0.7620 µm (30 µin) for 50 position connectors.
4. The Knoop microindentation hardness value shall be between 130 and 250 when measured in accordance with ASTM E384-05a using a load force of 0.245 N (25 g).
5. Test specimens shall exhibit no corrosion products having a diameter greater than 0.05 mm (0.002 in) when tested for porosity and other surface defects per EIA-364-53B.

#### 5.1.2 Nickel Barrier Layer

A nickel barrier layer shall be used between the gold surface layer and the base metal. It shall meet the following requirements:

1. The material content shall be 99.5% pure nickel minimum, and no other single component shall be more than 0.2%.
2. The minimum nickel thickness shall be 1.2700 µm (50 µin).
3. The nickel barrier layer shall not crack when a contact sample is bent through a 180° angle, with the plated surface away, around a mandrel whose diameter is equal to the thickness or diameter of the contact sample.

### 5.2 CONTACTS USING ALTERNATIVE MATERIALS

Alternative contact materials may be used for 6 and 8 position connectors provided they are compatible with hard gold contacts as specified in 5.1 and meet the equivalent performance requirements specified in this clause.

An alternative contact material shall be defined by a specification and shall meet all of its documented design requirements. The specification shall have sufficient detail to allow a competent independent laboratory to verify that the alternative material contact system complies with the design requirements. An inadequate interface specification, one that is too general or omits necessary information, is reason for rejecting the proposed alternative material interface.

### 5.2.1 Sample Selection

For evaluation purposes, samples of both plugs and jacks for both hard gold and alternative contact interface systems are required. The samples of alternative contact interface systems shall include, in addition to the proposed new alternative contact system, samples of all alternative contact systems previously shown to be equivalent to the hard gold contacts defined in 5.1.

The hard gold contact interface samples shall meet the requirement for a gold contact interface as defined in 5.1. Test samples should have gold plating thicknesses as close as practical to the 1.2700  $\mu\text{m}$  (50  $\mu\text{in}$ ) minimum permissible thickness. No connector contacts with more than 1.5240  $\mu\text{m}$  (60  $\mu\text{in}$ ) thick gold shall be used to evaluate alternative contact materials.

Alternative material contact samples representative of production units shall be selected so that the physical parameters of the test sample parts are on the side of the tolerance that would produce the least favorable test results. (An example would be the selection of parts with minimum plating thickness to produce minimum expected durability results.)

All sample plugs and jacks shall meet the relevant mechanical and dimensional requirements described in 4.3.

### 5.2.2 Mating and Unmating Forces Test

The mating and unmating forces test shall be performed in accordance with EIA-364-13B. Mating and unmating of the plug and jack shall be at a rate of 10mm/s (0.4 in/s). The following test procedure shall be used:

- (a) Select at least ten plug and jack sample pairs of each type for testing (e.g. 6-position/6-conductor or 8-position/8-conductor connector).
- (b) Insert plug into jack until latching tab locks.
- (c) Remove plug from jack by depressing latching tab.
- (d) Insert plug into jack until latching tab locks and measure mating force.
- (e) Remove plug from jack by depressing latching tab and measure unmating force.
- (f) Repeat step (b) and step (c) for 49 more cycles.
- (g) Repeat steps (d) and step (e).

The maximum mating force for each of the 10 samples shall not exceed 17.6 N (1.8 kg) and the maximum unmating force shall not exceed 7.35 N (0.75 kg).

### 5.2.3 Durability Test

The durability test shall be performed in accordance with EIA-364-09C. The following test procedure shall be used:

- (a) Select at least fifteen plug and jack sample pairs of each type for testing with a minimum of 60 contacts for each material combination.
- (b) Perform 250 mating/unmating cycles with a minimum interval between cycles of 5 s. Mating and unmating of the plug and jack shall be at a rate of 10 mm/s (0.4 in/s).
- (c) Perform chemical tests to determine contact plating breakthrough. For nickel-barrier plating systems, the modified sulfur dioxide ( $\text{SO}_2$ ) test method described



in Annex A should be used. Another approved chemical test method is the Nitric Acid Vapor Test per EIA-364-53B. For other types of barrier plating systems, test methods applicable for the type of material should be used.

- (d) When observed with 10x magnification, no more than 10% of the contacts tested shall be broken through in the wear track as indicated by products generated by the chemical reaction.

#### 5.2.4 Contact Resistance

The contact resistance shall be determined before and after subjecting samples of connectors to the temperature and humidity cycling test of 5.2.5 and the mixed flowing gas test of 5.2.6. The following test procedure shall be used:

- (a) Select two sets of connector samples with at least 80 total contacts in each set (i.e., a total of 160 contacts). All contacts in a particular plug-jack combination shall be tested.
- (b) Precondition both sets of samples by performing five mating and unmating cycles. These preconditioning cycles are to be performed at 20° C  $\pm$ 2° C, with no cleaning of the contacts permitted.
- (c) Determine the bulk resistance of the fixed connector between points A and B in Figure 5-1, by calculation or by measurement, for all contact pairs.
- (d) Determine the bulk resistance of the free connector between points B and C in Figure 5-1, by calculation or by measurement, for all contact pairs.
- (e) Measure the total mated connector resistance between points A and C in Figure 5-1, following the requirements and procedures of IEC 60512-2-1 for all contact pairs.
- (f) Calculate the contact resistance by subtracting the sum of the bulk resistances of the fixed and free connectors from the total mated connector resistance for all contact pairs.

$$\text{Contact resistance} = R_{AC} - (R_{AB} + R_{BC})$$

- (g) Subject one set of connector samples to the temperature and humidity cycling test of 5.2.5.
- (h) Subject the other set of connector samples to the mixed flowing gas test of 5.2.6.
- (i) Repeat steps (c) through (f) for both sets of samples.
- (j) Determine the change in contact resistance by subtracting the initial resistance from the final resistance for each contact pair.
- (k) For each set of samples, determine the average change in resistance for the four contact pairs that experience the greatest resistance increase.

The initial contact resistance shall not exceed 20 milliohms for any contact pair.

The average change in resistance for the four contact pairs with the greatest change in resistance as a result of the temperature and humidity cycling test of 5.2.5 shall not exceed 15 milliohms.

The average change in resistance for the four contact pairs with the greatest change in resistance as a result of the mixed flowing gas test of 5.2.6 shall not exceed 10 milliohms.

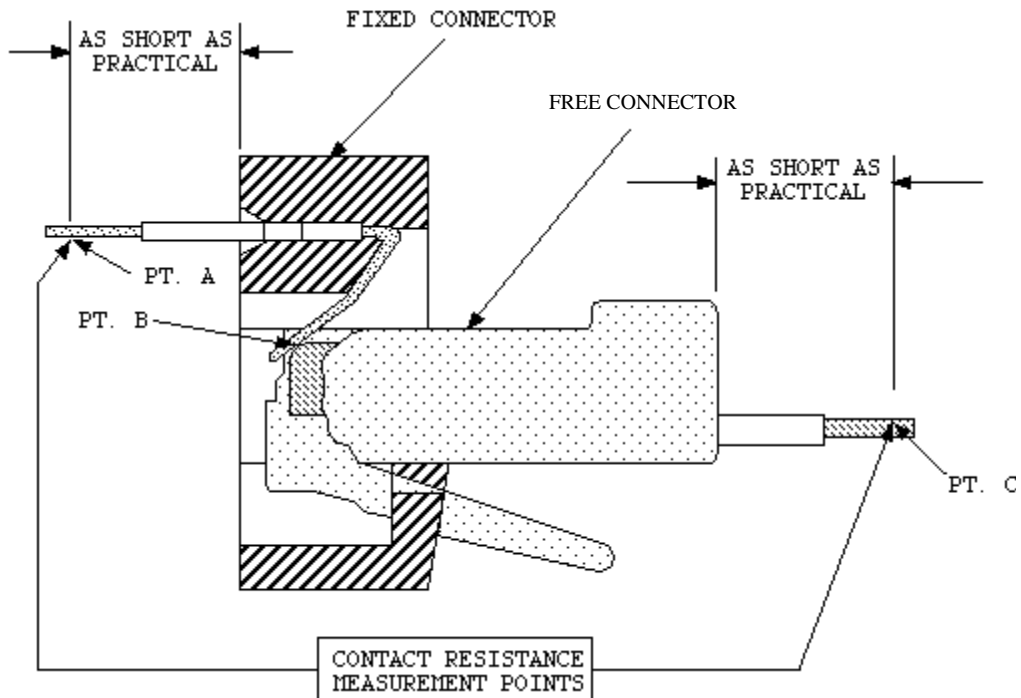

**Figure 5-1: Contact Resistance Connections**

### 5.2.5 Temperature and Humidity Cycling Test

Perform temperature and humidity cycling as follows:

- (a) Without disturbing the connector contact points after the initial contact resistance measurement in step (f) of 5.2.4, place one set of connector samples in a temperature and humidity chamber.
- (b) Cycle the chamber through the following test conditions:
  1. 30 minutes at 32° C (90° F) and 90% relative humidity;
  2. Two hour transition to -40° C (-40° F) and any reasonable humidity;
  3. 30 minutes at -40° C (-40° F) and any reasonable humidity;
  4. Two and one-half hour transition to 66° C (150° F) and 15% relative humidity;
  5. 30 minutes at 66° C (150° F) and 15% relative humidity;

6. Two-hour transition back to 32° C (90° F) and 90% relative humidity.
- (c) Repeat the temperature and humidity cycle of step (b) 49 times (i.e., all contacts are to be subjected to a total of 50 temperature and humidity cycles).
- (d) Allow 30 minutes for the samples to stabilize at room ambient temperature and humidity conditions. The connectors shall not be moved or contact points disturbed during this time.

Remeasure the contact resistance and determine the amount of resistance change as described in steps (i) through (k) of 5.2.4.

### **5.2.6 Mixed Flowing Gas Test**

The following procedure shall be used:

- (a) Without disturbing the connector contact points after the initial contact resistance measurement in step (f) of 5.2.4, place one set of connector samples in a suitable environmental test chamber.
- (b) Perform mixed flowing gas test as described in Annex B.
- (c) Allow two hours for the samples to stabilize at room ambient conditions.

Remeasure the contact resistance and determine the amount of resistance change as described in steps (i) through (k) of 5.2.4.

## **6 WIRING CONFIGURATIONS**

The connectors specified in this standard shall be wired in accordance with any of the applicable wiring configurations provided in T1.TR.5-1999.

## **ANNEX A (Informative) – MODIFIED SO<sub>2</sub> TEST METHOD**

The modified sulfur dioxide (SO<sub>2</sub>) test procedure consists of the following steps:

- (1) Wash samples in distilled water.
- (2) Rinse samples in isopropyl alcohol.
- (3) Allow samples to air dry (not blown).
- (4) Place 100 ml of sulfurous acid in a 10-liter desiccator and allow to stand for 30 minutes.
- (5) Suspend samples in chamber for 24 hours at ambient temperature without touching solution.
- (6) After exposure, dry samples at 80° C for 10 minutes.
- (7) Prepare saturated dimethylglyoxime (DMG) solution in ethanol.
- (8) Mix one part of above with one part concentrated ammonium hydroxide.
- (9) Apply mixture of Step (h) to samples. The solution should completely wet samples by aerosol spraying, immersion, or swabbing.
- (10) Allow samples to air dry (not blown).
- (11) Nickel exposure is indicated by a pink colored corrosion product.

NOTE: After drying, white crystals on surface are dried DMG. Nickel will show as a pink colored corrosion product while base metal would have shown as a corrosion product after exposure to sulfurous acid.

## **ANNEX B (Normative) – MIXED FLOWING GAS TEST**

### **B.1 GENERAL**

In the evaluation of contact interfaces for gold equivalency, it is necessary to evaluate the contact interface performance when exposed to a corrosive atmosphere. A corrosive atmosphere is best simulated by a mixed flowing gas test. Since such a test has not yet been standardized, it is necessary to include a complete mixed flowing gas test procedure in this Document.

The procedure selected is based upon Project TP-65 draft text developed by EIA Engineering Committee P5.1 and is representative of the type of test being conducted by the connector industry at present. If a procedure for mixed flowing gas testing is standardized, it will be considered for use in replacing this annex

#### **B.1.1 Content**

This annex covers the test procedure for producing environmentally related corrosive atmospheres to determine the reaction of plated or unplated surfaces when exposed to different concentrations of flowing gas mixtures.

#### **B.1.2 Description**

Samples which are to be evaluated may be mated or unmated connectors, components, or experimental materials. They are placed in an environmentally controlled chamber that is monitored by a gas analyzing system for controlled concentrations of the gas mixture. Corrosion rates are monitored by silver and copper control coupons placed in the chamber for each test. These control coupons are removed and analyzed using calometric reduction for factors related to amount and type of corrosive product growth to confirm severity control level.

#### **B.1.3 Safety**

This procedure involves the use of hazardous materials, operations, and equipment. This annex does not purport to address all of the safety concerns that may be associated with its use. It is the responsibility of the user of this annex to consult and establish appropriate safety and health practices and determine the applicability of regulatory limitations prior to use. For specific precautions, see B.4.

### **B.2 MATERIALS**

#### (1) Control Coupons

- (a) Copper sheet, oxygen free high conductivity, UNS C10200, 0.0127 mm (0.005 inch) thick, temper 0.5 hard.
- (b) Silver foil, pure fine grain, 0.0127 mm (0.005 inch) thick.
- (c) Acid, sulfuric, concentrated, AR grade.
- (d) Jewelers Rouge.
- (e) 1,1,1 Trichloroethane, AR grade.

- (f) Deionized or distilled water.
  - (g) Hydrochloric Acid, AR grade.
  - (h) Methanol, AR grade.
- (2) Exposure Materials
- (a) Nitrogen gas, pro-purified grade or better.
  - (b) Nitrogen dioxide gas, chemically pure grade or better.
  - (c) Hydrogen sulfide gas, chemically pure grade or better.
  - (d) Chlorine gas, chemically pure grade or better.
  - (e) Clean, dry and oil-free air.
  - (f) Gas injection equipment, for example, Teflon permeation tubes.

### **B.3 TEST EQUIPMENT**

(1) Coupon Evaluation Equipment

(a) Coulometric Analyzer

Coulometry for IMFG monitoring is limited to determination of sulfide and oxide films on copper, and sulfide and chloride films on silver. Experience has shown that monitoring these films is usually sufficient to validate the IMFG environmental conditions of the chamber.

(b) Weight gain equipment

(c) Other

NOTE: provided correlation with coulometric method has been demonstrated.

(2) Environmental Chamber

(a) The environmental chamber is to consist of an enclosure made of noncorrosive, nonmetallic materials contained within a cabinet, oven, or incubator capable of maintaining the temperature within the specified ranges, see Table B-1. A commercially available environmental chamber will suffice.

(b) The constant temperature chamber for permeation tubes, if used, is to be capable of controlling the temperature within  $\pm 1^\circ$  C over a temperature range of 15-30 $^\circ$  C.

(3) Source of clean dry air

(4) Appropriate gas analysis equipment for calibrating and monitoring the gas concentrations in the chamber. The gas analysis equipment is to be capable of the following accuracy:

Total Sulfur Analyzer	$\pm 1$ ppb at 20% upper range limit $\pm 4$ ppb at 80% upper range limit
NO <sub>2</sub> Analyzer	$\pm 1$ ppb at 20% upper range limit $\pm 4$ ppb at 80% upper range limit

Cl<sub>2</sub> Analyzer ±4%

- (5) Temperature and humidity monitoring equipment, capable of an accuracy of ±0.5° C and ±1% relative humidity, respectively.

## B.4 SAFETY AND HEALTH CONSIDERATIONS

Do not perform these procedures unless the operator is fully trained in handling hazardous materials and knowledgeable of the appropriate precautions necessary to perform this test. Appropriate safety and health representatives should be consulted for any other prerequisites or proper procedures prior to performing this specification. The safety and environmental procedures to observe include, but are not limited to, the following items:

- (1) Material Safety Data Sheets with first aid information have been obtained for all chemicals used both in cleaning and testing.
- (2) The operator has received the Safety Sheets and become familiar with normal precautions for handling corrosive and toxic materials.
- (3) All necessary safety equipment is available including a properly functioning, well lighted fume hood, eyewash station/shower, large sink with running water, acid resistant glove and apron, chemical goggles and acid spill kit.
- (4) All chemicals have been properly labeled and will be properly stored in accordance with Occupational Safety and Health Administration (OSHA) and Environmental Protection Agency (EPA) Regulations.
- (5) Arrangements for proper storage and disposal of chemicals have been made.

## B.5 SAMPLE PREPARATION

### B.5.1 Control Coupon Preparation

This is a critical process in conducting the test and therefore the same method should be used each time the test is performed. Improper cleaning may introduce contaminants that can affect the corrosion rates and mechanisms. The following method has been found to produce reproducible results.

**WARNING! PERFORM ALL WORK WITH ACIDS, SOLVENTS, OR GASES IN A FUME HOOD. CHEMICAL GOGGLES, OR FACE SHIELD, SHALL BE WORN. OBSERVE PRECAUTIONS IN HANDLING CORROSIVE AGENTS.**

- (1) Copper
  - (a) Vapor degrease with 1,1,1 trichloroethane or equivalent for 1 minute.
  - (b) Rinse thoroughly with methanol.
  - (c) Rinse thoroughly with deionized or distilled water.
  - (d) Etch with 15% solution of sulfuric acid at 50° C for 2 minutes.
  - (e) Rinse with deionized or distilled water.
  - (f) Dry with clean, dry, filtered air.

(2) Silver

- (a) Dip in concentrated hydrochloric acid for 2 minutes.
- (b) Rinse with deionized or distilled water.
- (c) Dry with clean, dry, filtered air.
- (d) Buff with jewelers rouge.
- (e) Ultrasonically clean with 1,1,1 trichloroethane or equivalent for 1 minute.
- (f) Repeat cleaning with fresh 1,1,1 trichloroethane.
- (g) Air dry (not blown).
- (h) Vapor degrease with 1,1,1 trichloroethane or equivalent for 1 minute.
- (i) Air dry (not blown).
- (j) Clean cathodically in a boiling solution of trisodium phosphate using an inert anode for 1 minute at a current of 1.0 ampere.
- (k) Rinse thoroughly with distilled or deionized water.
- (l) Dry with clean, dry, filtered air.

NOTES:

- (1) Control coupons should be handled with clean forceps at all times with the exception the of buffing in Step (d) above.
- (2) Store coupons in a sealed container that has been filled with an inert gas (i.e., nitrogen), or an evacuated desiccator until used.

### B.5.2 Test Sample Preparation

Samples are to be tested in the "as received condition" unless otherwise specified. All surfaces that are not intended for exposure and could influence the various measurements are to be protected.

## B.6 PROCEDURE

### B.6.1 Calibration

**WARNING! PERFORM ALL WORK WITH ACIDS, SOLVENTS, OR GASES IN A FUME HOOD. CHEMICAL GOGGLES, OR FACE SHIELD, SHALL BE WORN. OBSERVE PRECAUTIONS IN HANDLING CORROSIVE AGENTS.**

Prior to the start of a test, all gas concentration monitoring equipment is to be calibrated by the operator to known standards following procedures outlined by the equipment manufacturers. After start of the test, the monitoring equipment is to be calibrated at least every 5 days and on the final day of testing in order to ensure that the readings are accurate.

NOTE: Some chlorine monitors cannot differentiate between chlorine and some other pollutant gases. Those monitors will only require calibration prior to the beginning of testing and just after the final day of testing as



these are the only times that the other gases can be eliminated from the chamber to allow a determination of the chlorine levels.

### B.6.2 Pretest Procedures

- (1) Adjust humidity and temperature according to environmental severity class specified as indicated in Table B-1, without samples in chamber.
- (2) Allow chamber to stabilize for temperature and humidity without samples. Exchange rate is to be adjusted to provide 6 changes per hour.
- (3) Currently, chlorine concentration is to be adjusted and stabilized first; this gas cannot be monitored in combination with the other pollutants.
- (4) Figure B-1 defines the zone configuration of a typical test chamber. Control coupons are to be placed in the shaded zones of Figure B-2. Inert, noncorrosive materials are to be used for suspending the test samples and control coupons in the test chamber.
- (5) Place samples and control coupons in chamber as soon as possible after stabilization period. They are to be placed such that there is a minimum space of 5.1 cm (2 inches) between samples, coupons and the chamber walls. Random placement of the samples at the various measurement intervals throughout the test is important.
- (6) Sample orientation is to be chosen to minimize obstruction of the air flow.
- (7) Because of absorption of gases by the samples, allow chlorine concentrations to stabilize and adjust, if necessary, to the desired concentration.
- (8) The remaining pollutants (NO<sub>2</sub> and H<sub>2</sub>S) are then to be introduced into the test chamber and adjusted for the concentrations of the requested exposure class in Table B-1.
- (9) Total reactive corrosion area of samples and control coupons compared to the volume in inner chamber is to be such that the concentrations of the gasses can be maintained throughout the test.

**Table B- 1: Environmental Severity Limits**

Environmental Class	% Relative Humidity	Temperature °C	Pollutant Concentration (ppb)		
			Cl <sub>2</sub>	NO <sub>2</sub>	H <sub>2</sub> S
I	Discontinued as a test procedure				
II	70 ±2	30 ±2	10 ±3	200 ±50	10 ±5
III	75 ±2	30 ±2	20 ±5	200 ±50	100 ±20
IV	75 ±2	40 ±2	30 ±5	200 ±50	200 ±20

### B.6.3 Test Procedures

**WARNING! PERFORM ALL WORK WITH ACIDS, SOLVENTS, OR GASES IN A FUME HOOD. CHEMICAL GOGGLES, OR FACE SHIELD, SHALL BE WORN. OBSERVE PRECAUTIONS IN HANDLING CORROSIVE AGENTS.**

- (1) A recommended exposure time for the test samples is 20 days unless otherwise specified in the referencing document.
- (2) In many cases it may be advantageous to withdraw samples for periodic testing prior to the full time of the test. After removal from the chamber, such samples are to be stabilized at ambient room temperature for a minimum of 2 hours, measured for appropriate response, and returned to the chamber if required. Such withdrawals are to be noted in the test report.
- (3) The interior of the environmental chamber is to be monitored daily for humidity, temperature, and pollutant concentration. If adjustment is required, additional monitoring is to be performed. Concentration of chlorine gas is to be adjusted only at the start of the test and checked at the completion of the test, since chlorine concentration cannot be analyzed in combination with the other pollutants. However, the initial chlorine flow rate is to be maintained throughout the test.
- (4) At the conclusion of the test, the test samples is to be removed from the chamber and stabilized at ambient room temperature for a minimum of 2 hours before making the final readings or measurements.

### B.6.4 Control Coupon Exposures

**WARNING! PERFORM ALL WORK WITH ACIDS, SOLVENTS, OR GASES IN A FUME HOOD. CHEMICAL GOGGLES, OR FACE SHIELD, SHALL BE WORN. OBSERVE PRECAUTIONS IN HANDLING CORROSIVE AGENTS.**

- (1) A minimum of 3 coupons each of copper and silver, for each time interval and location in the test chamber, is to be placed in the chamber to monitor corrosion film growth rates. A minimum of 3 coupons of each type are to be removed after an exposure time of 48 hours, and a minimum of another 3 coupons of each type after 95 hours. A new set of coupons are to then be placed in the chamber to monitor the next major time interval, and again a minimum of 3 coupons of each type are to be removed after the 48 and 95 hour exposure time.
- (2) Recommended major time intervals during a typical 20-day test are as follows:
  - (a) between the 1st and 4th day of the test;
  - (b) between the 9th and 12th day; and,
  - (c) from the 16th through the 20th day.
- (3) Control coupons are used to monitor the reaction rate in the chamber and not the deterioration of the test samples. Coupons removed from the chamber are not to be returned to the chamber.

- (4) Whenever possible, in order to minimize instability of the test conditions within the chamber, any test samples required to be removed on a certain day is to be removed at the same time as the control coupons are being removed or replaced.

### **B.6.5 Control Coupon Evaluation**

Control coupons removed from the chamber are to be analyzed using any method in B.3 to verify chamber conditions.

## **B.7 DOCUMENTATION**

Data Sheets are to contain:

- (1) title of test;
- (2) sample description;
- (3) test equipment;
- (4) number of samples;
- (5) test procedure;
- (6) actual pollutant concentrations used in the test (H<sub>2</sub>S, NO<sub>2</sub>, Cl<sub>2</sub>);
- (7) deviations from test conditions during sample exposure (charts to be supplied if necessary);
- (8) date of test and name of operator.

## **B.8 SUMMARY**

The following details are to be specified in the referencing document:

- (1) number of samples to be tested;
- (2) duration of exposure, if other than specified in B.3, Step (1);
- (3) test severity class;
- (4) sample preparation and descriptions of product to be tested;
- (5) sample measurement intervals.

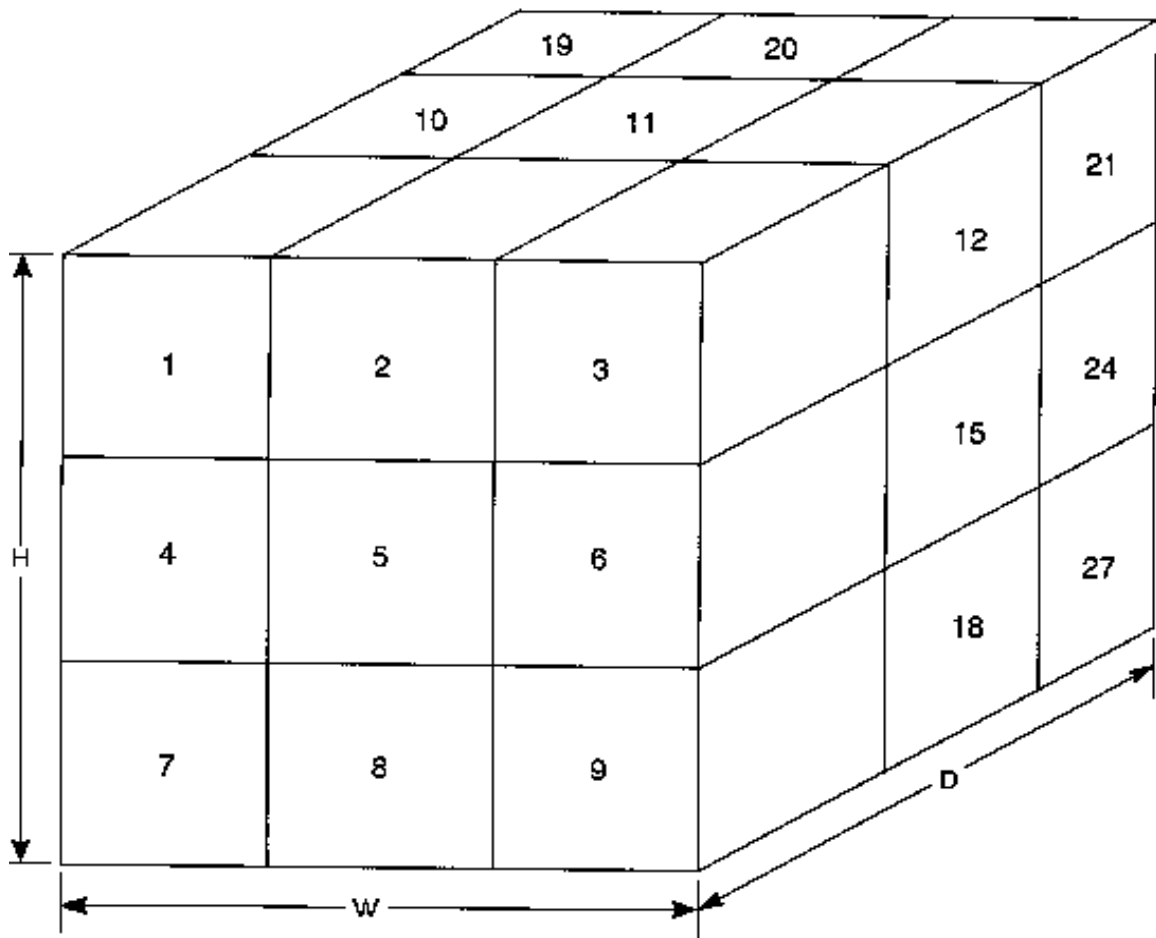

**Figure B- 1: Chamber Zone Configuration**

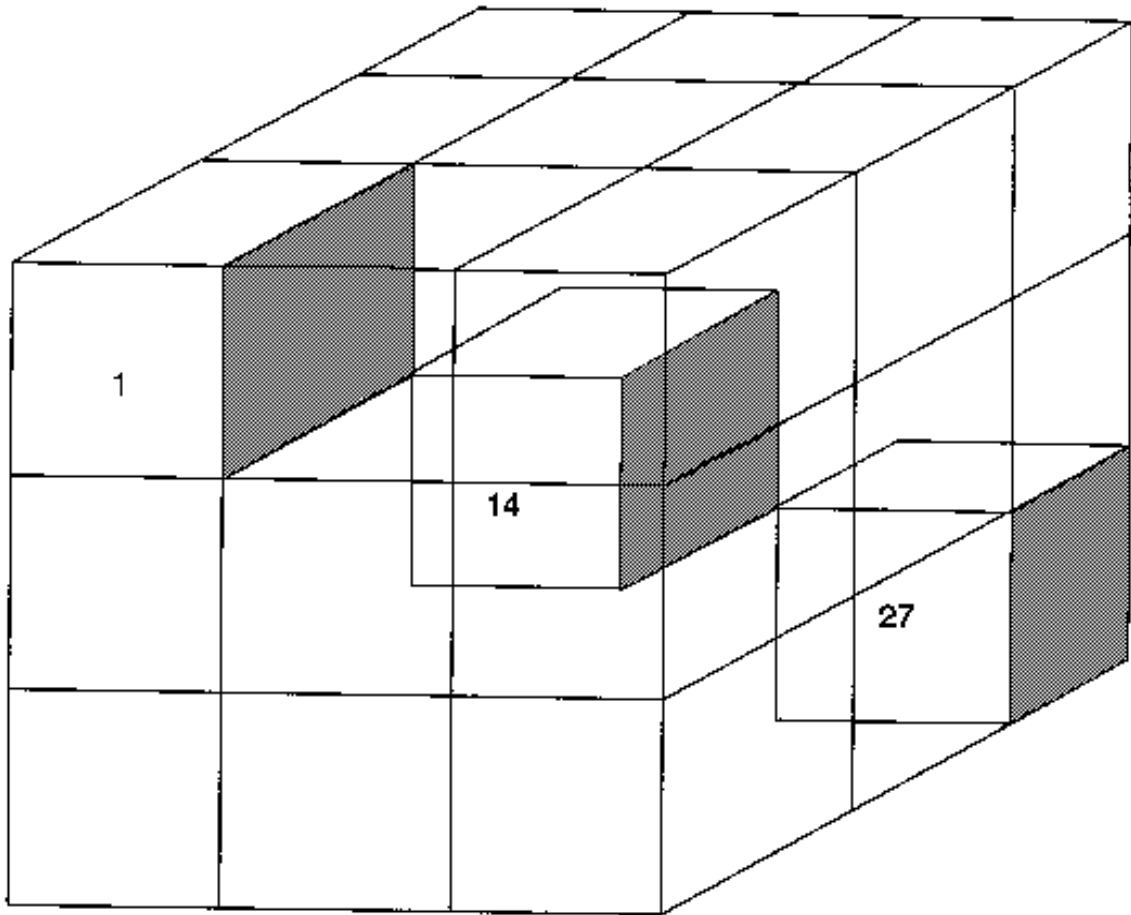

**Figure B- 2: Control Coupon Locations**





